

# NCAA Women's Flag Football 2025

---

Rule 1	The Game, Field, Players, and Equipment
Rule 2	Definitions
Rule 3	Periods, Time Factors, and Substitutions
Rule 4	Ball in play, Dead-ball, Out-of-bounds
Rule 5	Series of Downs, Line to Gain
Rule 6	Kicks
Rule 7	Snapping, Passing, and Running
Rule 8	Scoring
Rule 9	Conduct of Players and Others Subject to the Rules
Rule 10	Penalty Enforcement
Rule 11	The Officials: Jurisdiction and Duties

# RULE 1

## The Game, Field, Players, and Equipment

---

### SECTION 1. General Provisions

#### The Game

**ARTICLE 1.** The game shall be played between two teams of no more than seven players each, on a rectangle field and with an inflated ball having the shape of a prolate spheroid. A team may legally play with fewer than seven players.

#### Goal Lines

**ARTICLE 2.** Goal lines, one for each team, shall be established at opposite ends of the field of play, and each team shall be allowed opportunities to advance the ball across the other team's goal line by running or passing it.

#### Winning Team and Final Score

**ARTICLE 3. a.** The teams shall be awarded points for scoring according to rule and, unless the game is forfeited, the team having the larger score at the end of the game shall be the winning team.

**b.** When the referee declares that the game has ended, the score is final.

#### Game Officials

**ARTICLE 4.** The game shall be played under the supervision of the game officials.

#### Team Captains

**ARTICLE 5.** Each team shall designate to the referee not more than four players as its field captain(s). One player at a time shall speak for their team in all dealings with the officials.

#### Persons Subject to the Rules

**ARTICLE 6. a.** All persons subject to the rules are governed by the decisions of the officials.

**b.** Those persons subject to the rules are: Everyone in the team area, players, substitutes, replaced players, coaches, athletics trainers, cheerleaders, band members, mascots, public-address announcers, audio/visual/lighting system operators, and other persons affiliated with the teams or institutions.

## SECTION 2. The Field

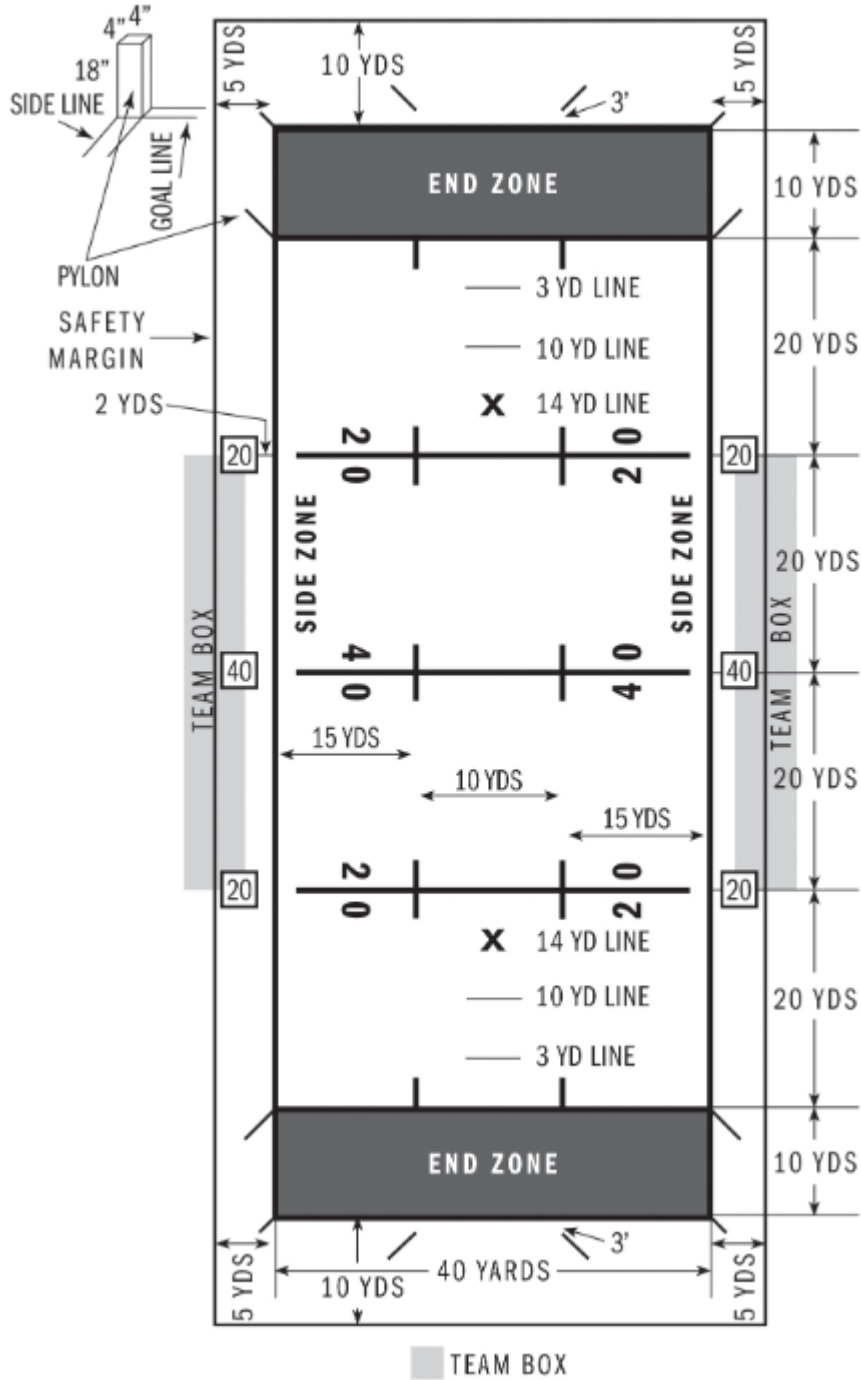

## **Dimensions**

**ARTICLE 1.** The field shall be a rectangular area with dimensions, lines, zones, goals, and pylons indicated in Appendix X. If using a tackle football field, the dimensions and zones will be set to those specific to 7 on 7 flag football.

## **Field Markings**

**ARTICLE 2.** The width of the field shall be lined at 20-yard intervals from goal line to goal line. All yard lines inside the boundaries shall stop 4" from each sideline. Hash marks are required and must be present. They shall run parallel with each sideline, located 15 yards "in" from each sideline. The 3 and 10-yard Try lines shall be 2 yards wide and 4" thick. Both 14-yard lines shall be marked with an "X" or appropriate indicator and shall have a height of 1 yard and a line thickness of 4". White is the recommended color for all field markings.

## **Limit Lines**

**ARTICLE 3. a.** Limit lines shall be marked 12 feet outside the sidelines and the end lines. Limit lines designating team areas shall be solid lines.

- b.** No person outside the team area shall be inside the limit lines. Game management personnel have the responsibility and the authority to enforce this rule. (**Exception:** Hand-held cameras under the supervision of the television partners may briefly be between the limit lines and the sideline after the ball is dead and the game clock has been stopped. This exception does not allow cameras to be on the field of play or in the end zone at any time).
- c.** Limit lines shall also be marked six feet from the team area around the side and back of the team area, if the stadium permits.

## **Goal Line.**

**ARTICLE 4.** The entire width of the goal line shall be part of the end zone.

## **Team Box**

**ARTICLE 5. a.** Each side of the field shall have a team box designated for the players and non-players. This team box shall be located a minimum of five (5) yards from the sideline, between the twenty (20) yard lines on both sides of the field. The home team shall have a designated home side, usually the side of the field with the press box. All team members who are not participating in the play shall remain in the Team Box during live-balls.

- b.** The team area shall be limited to squad members in full uniform. All persons in the team area are subject to the rules and are governed by decisions of the officials (Rule 1-1-6). The individuals not in full uniform shall wear special team area or university credentials.
- c.** Coaches are permitted in the coaching box (see Appendix X), which is the area bounded by the limit line and coaching line between the 20-yard lines.
- d.** No media personnel, including journalists, radio and television personnel, or their equipment, shall be in the team area or coaching box, and no media personnel shall communicate in any way with persons in the team area or coaching box. In stadiums where the team area extends to the spectator seating area, a pass-through area should be made available for media to move from one end of the field to the other on both sides of the field.
- e.** Game management personnel shall remove all persons not authorized by rule.

## **End Zone Pylons**

**ARTICLE 6.** Soft, flexible four-sided pylons 4 inches by 4 inches with an overall height of 18 inches, which may include a 2-inch space between the bottom of the pylon and the ground, are required. They shall be red or orange in color. They are placed at the inside corners of the eight intersections of the sidelines with the goal lines and end lines. The pylons marking the intersections of the end lines and hash marks extended shall be placed three feet off the end lines.

## **Sideline Zone Markers, Down Indicators and Line-to-Gain Markers.**

**ARTICLE 7.** Each line to gain, both 20-yard lines and the 40-yard line, shall have yard-line markers constructed of a soft and pliable material, which shall be located three (3) yards from the side lines. Team members shall remain behind the markers in the team box while not participating in the game.

### **Field Numbers**

**ARTICLE 8.** White field yard line numbers shall be 6' in height and 4' in width, with the tops of the numbers 5 yards from the sidelines, if used.

### **Obstructions**

**ARTICLE 9. a.** All obstructions within the playing enclosure shall be placed or constructed in such a manner as to avoid any possible hazard to players. This includes anything dangerous to anyone at the limit lines.

**b.** After the officials' pregame inspection of the playing enclosure, the referee shall order any hazardous obstructions located inside the limit lines removed.

**c.** The referee shall report to game management personnel any obstructions constituting a hazard within the playing enclosure but outside the limit lines. Final determination of corrective action shall be the responsibility of game management personnel.

**d.** After the officials have completed their pregame inspection of the playing enclosure, it is the responsibility of game management personnel to ensure that the playing enclosure remains safe throughout the game.

### **Field Surface and Slope**

**ARTICLE 10. a.** No material or device shall be used to improve or degrade the playing surface or other conditions and give one player or team an advantage.

**b.** The referee may require any improvement in the field necessary for proper and safe game administration.

**c.** It is recommended there be a slope of 1/4" per foot from the center of the field to each sideline on a natural grass field.

## **Section 3. Game Equipment**

### **The Ball**

**ARTICLE 1.** The ball shall meet the following specifications:

- a.** New or nearly new. (A nearly new ball is a ball that has not been altered and retains the properties and qualities of a new ball).
- b.** A tan-colored cover consisting of pebbled-grain, cowhide, or approved composition (leather) case without corrugations other than those formed by the natural seam and the lace on one of the grooves.
- c.** Laces shall be spaced evenly in a set of eight (8) or twelve (12). The lace shall begin and end 3 ¾ inches from either end of the ball.
- d.** It shall weigh between 12 and 13 ounces while inflated to 12-½ to 13-½ pounds per square inch (psi).
- e.** Each ball shall bear the authenticating mark.
- f.** Advertising is prohibited on the ball. All balls shall contain only the following permissible items:
  - 1.** School name and/or logo.
  - 2.** Conference name and/or logo.
  - 3.** Ball manufactures name and/or logo.

The referee shall have the final decision on all balls which each team intends on using during the game.

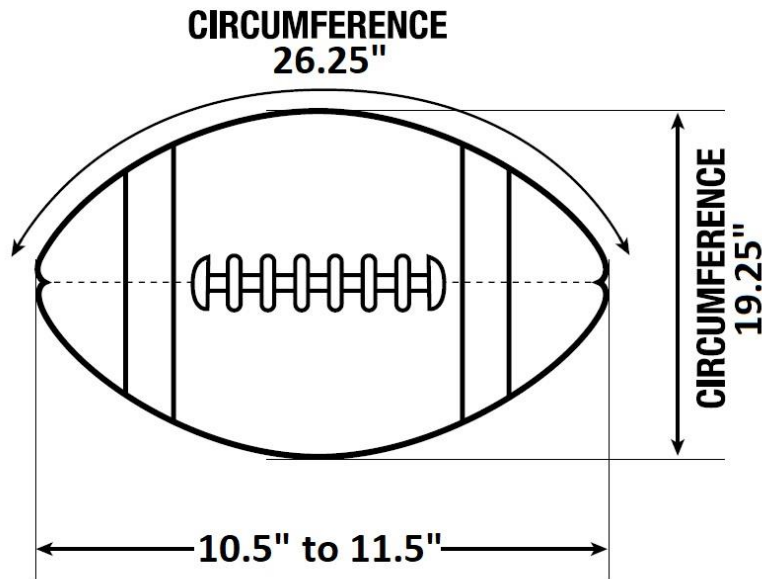

#### Down Box

**ARTICLE 2.** One down box shall be used to indicate the number of the down and shall be placed at the nearest line to gain. It shall be placed three yards from the sideline, directly behind the marker. During the try the down box shall be placed at the goal line, and it shall display the point value which has been declared by Team A. One additional down box will be utilized at the line of scrimmage approximately 3 yards from the sideline, directly behind the Line Judge. This box must be operated on the side of the field opposite the press box. It will also indicate the number of the down.

### Section 4. Players and Playing Equipment

#### Jersey

##### ARTICLE 1. a. Design.

1. The jersey may not be altered or designed to tear. The jersey must be full-length to be tucked into the pants. No other undergarment shall extend below the waistline at the torso. Vests and/or altered jerseys with zippers, Velcro, clasps, or other fasteners are not allowed.
2. Other than the player's number, the jersey may only contain:
  - Player's name.
  - School name.
  - Mascot name.
  - Sleeve Stripes.
  - Logo for school, conference, mascot, postseason-game, memorial, the military.
  - Graduate or academic recognition as part of an institutional or conference logo.
  - The letter "C" to identify a team captain.
  - American flag.
  - State flag.
3. Jerseys may not be taped or tied in any manner.

##### b. Color.

1. Players of opposing teams shall wear contrasting colored jerseys, without pockets, numbered on the front and rear. Players of the same team shall wear jerseys of the same color and design. The jersey includes:

- (a) Shirt and undershirts.
  - (b) Pants and shorts.
  - (c) Headgear.
  - (d) Sweatbands and armbands
  - (e) Socks.
  - (f) Gloves.
  - (e) Shoes.
2. The visiting team shall wear white jerseys; however, the home team may wear white jerseys if agreed to in writing prior to the game.

### **Players' Numbering**

**ARTICLE 2. a.** All players shall be numbered 0 through 99. Any number preceded by the digit 0 such as "04" or "00" is illegal.

- 1. The numbers must be clearly visible, permanent Arabic numerals measuring at least 8 and 10 inches in front and back, respectively.
- b. No two players of the same team shall participate in the same down wearing identical numbers.

### **Pants/Shorts**

**ARTICLE 3.** Players shall wear pants or shorts, which shall not have pockets of any type, zippers, exposed drawstrings, belts, and/or belt loops. The pants/shorts shall be in contrasting color from the flags.

### **Flag Belt**

**ARTICLE 4.** Each player shall wear a one piece, size appropriate belt without knots at the waistline with two (2) permanently attached standard pop flag holsters, accompanied by two standard pop flags. When worn correctly, there shall be 1 flag on each hip. If the flags are not located as indicated, then the offending player shall be asked to readjust their flags until they are set in legal position. The dimensions of the flags shall be no less than 1-<sup>3</sup>/<sub>4</sub> inches wide and no less than 14-inches long when measured from the top edge of the belt. Excess material around the waist belt shall be tucked away or removed.

### **Mouthpiece**

**ARTICLE 5.** Each player shall wear a mouthpiece. The mouthpiece must be an intra-oral device of readily visible color. It must not be white or transparent. It must be made with FDA-approved base materials and cover all upper teeth. It is recommended that the mouthpiece be properly fitted.

### **Gloves**

**ARTICLE 6. a.** A glove is a fitted covering for a hand having separate sections for each finger and thumb without connected webbing. There is no restriction on color.

- b. Gloves may be worn if they are made of a soft, non-abrasive, non-hardening material which meets the standards of, has been sanctioned by, and bears the logo of the approved sanctioning organization, unless made of unaltered plain cloth.

### **Head Gear**

**ARTICLE 7. a.** Players may wear a soft helmet which meets the standards, has been sanctioned and wears the logo of a proper sanctioning organization.

- b. Players shall not wear hats with a hard brim.
- c. Headbands and hats are legal provided they are not considered dangerous to any player. They shall be made of nonabrasive cloth and the only logos permitted are the manufacturers and/or the school logo.

### **Pads**

**ARTICLE 8.** Pads may be worn on the lower leg, knee, and ankle, if the material is soft and pliable. Soft yielding padded compression shorts and/or shirts may be worn underneath the players jersey, pants and/or shorts.

### **Play Books**

**ARTICLE 9.** Players may wear a soft, pliable wrist/forearm band that contains plays. No playbook may be worn around the waist or flag belt.

### **Eye Wear**

**ARTICLE 10.** Sports Eyewear specifically produced which are non-rigid, without sharp edges, have shatter proof lenses, and are non-tinted may be worn. No medical exceptions are allowed.

### **Face Shield**

**ARTICLE 11.** Only a physician approved nose protectant face shield is allowable.

### **Illegal Player Equipment**

**ARTICLE 12.** A player who is not properly equipped shall not be permitted to participate until the illegal equipment has either been repaired or removed. This applies to all equipment which an official deems dangerous and/or confusing. Types of equipment or substances which shall always be declared illegal include the following:

- a. Equipment worn by a player that could endanger other players.
- b. Pants or shorts with any belts, belt loops, pockets, zippers, or exposed drawstrings
- c. Jewelry of any type, except for a medical bracelet.
- d. Headgear other than that approved in Rule 1-4-7.
- e. Casts and braces worn above the waist.
- f. Jerseys which do not remain tucked in.
- g. Hoods of any type.
- h. Shoes with metal cleats.
- i. Exposed metal on the uniform or clothing of a player. This includes "O" or "D" rings used to secure flag belts.
- j. Towels, hand warmers, playbooks, and other items not specifically approved according to rule attached at the players waist.

**PENALTY—Unsportsmanlike Conduct, Illegal Player Equipment, Ten yards.**

### **Missing or Illegal Player Equipment**

**ARTICLE 13.** When any required player equipment is missing or when illegal equipment is found on any incoming substitute or player, correction shall be made before participation. Players will be sent off the field to correct the issue.

### **Coaches' Field Equipment**

**ARTICLE 14.** Local Area Network (LAN) phones and/or headsets may be used by coaches, other nonplayers, and players. However, players may use LAN phones and/or headsets only during authorized sideline conferences.

**PENALTY—Unsportsmanlike Conduct, Ten yards.**

### **Referee Communication**

**ARTICLE 15. a.** A microphone is strongly encouraged for the referee to be used for all game announcements. It is strongly recommended that it be a lapel-type microphone. The microphone must be controlled by the referee. It may not be open at other times. Microphones on other officials are prohibited.

**b.** A protected wireless official-to-official communication system open only to the officiating crew is permitted.

# RULE 2

## Definitions

---

### SECTION 1. The Ball: Live, Dead, Loose, Ready for Play

#### Live-ball

**ARTICLE 1.** A live-ball is a ball in play. A pass, kick or fumble that has not yet touched the ground is a live-ball in flight.

#### Dead-ball

**ARTICLE 2.** A dead-ball is a ball not in play.

#### Loose Ball

**ARTICLE 3. a.** A loose ball is a pass, fumble, or a kick. A loose ball that has not yet touched the ground is in flight. A grounded loose ball is one that has touched the ground. Any loose ball continues to be a loose ball until a player secures possession of it or until it becomes dead by Rule, whichever comes first.

**b.** All players are eligible to touch, catch or recover a fumble or a backward pass in flight.

**c.** Eligibility to touch a kick is governed by kick rules (Rule 6).

**d.** All players are eligible to touch a forward pass (Rule 7).

#### When Ball Is Ready for Play

**ARTICLE 4.** A dead-ball is ready for play when:

**a.** With the 40-second play clock running, an official places the ball at a hash mark or between the inbounds marks and steps away to their position.

**b.** With the play clock set at 25 seconds, or at 40 seconds after an injury to a defensive player, the referee sounds their whistle and either signals to start the game clock or signals that the ball is ready for play.

### SECTION 2. Blocking

#### Blocking

**ARTICLE 1.** Screen blocking is legally obstructing an opponent without using any part of the body to initiate contact and while remaining within the frame of the body.

#### Frame of the Body

**ARTICLE 2.** The frame of a player's body is at the shoulders or below other than the back. It does not include extended limbs.

### SECTION 3. Catch, Recovery, Possession

#### Possession

**ARTICLE 1.** Possession refers to custody of (a) a live-ball as described later in this article and (b) a dead-ball to be snapped. It may refer either to player possession or team possession.

**a.** Player Possession.

The ball is in player possession when a player has the ball firmly in their grasp by holding or controlling it with hand(s) or arm(s) while contacting the ground inbounds.

**b.** Team Possession.

The ball is in team possession:

**1.** When one of its players has player possession, including when they are attempting a kick; or

**2.** While a forward pass thrown by a player of that team is in flight; or

3. During a loose ball if a player of that team last had player possession; or
  4. When the team is next to snap the ball.
- c. A team is in legal possession if it has team possession when its players are eligible to catch or recover the ball.

#### **Belongs To**

**ARTICLE 2.** “Belongs to,” as contrasted with “in possession”, denotes custody of a dead-ball. Such custody may be temporary, because the ball must next be put in play in accordance with rules governing the existing situation.

#### **Catch, Interception, Recovery**

**ARTICLE 3. a.** To catch a ball means that a player:

1. Secures firm control with the hand(s) or arm(s) of a live-ball in flight before the ball touches the ground, and
  2. Touches the ground inbounds with any part of the body, and then
  3. Maintains control of the ball long enough to enable that player to perform an act common to the game, i.e., long enough to pitch or hand the ball, advance it, avoid an opponent, etc., and
  4. Satisfies paragraphs b, c, and d below.
- b. If a player goes to the ground in the act of catching a pass (with or without contact by an opponent) the player must maintain complete and continuous control of the ball throughout the process of contacting the ground, whether in the field of play or in the end zone. This is also required for a player attempting to make a catch at the sideline and going to the ground out-of-bounds. If the player loses control of the ball which then touches the ground before they regain control, it is not a catch. If the player regains control inbounds prior to the ball touching the ground it is a catch.
- c. If the player loses control of the ball while simultaneously touching the ground with any part of their body, or if there is doubt that the acts were simultaneous, it is not a catch. If a player has control of the ball, a slight movement of the ball, even if it touches the ground, will not be considered loss of possession; the player must lose control of the ball for there to be a loss of possession.
- d. If the ball touches the ground after the player secures control and continues to maintain control, and the elements above are satisfied, it is a catch.
- e. An interception is a catch of an opponent’s pass or fumble.
- f. A catch by any kneeling or prone inbounds player is a completion or interception.
- g. A player recovers a ball if they fulfill the criteria in paragraphs a, b, c, and d for catching a ball that is still alive after hitting the ground.
- h. When in question, the catch, recovery or interception is not completed.

#### **Simultaneous Catch or Recovery**

**ARTICLE 4.** A simultaneous catch or recovery is a catch or recovery in which there is joint possession of a live-ball by opposing players inbounds.

### **SECTION 4. Down, Between Downs and Loss of Down**

#### **Down**

**ARTICLE 1.** A down is a unit of the game that starts after the ball is ready for play with a legal snap and ends when the ball becomes dead.

#### **Between Downs**

**ARTICLE 2.** Between downs is the interval during which the ball is dead.

#### **Loss of Down**

**ARTICLE 3.** “Loss of down” is an abbreviation meaning “loss of the right to repeat a down”.

## **SECTION 5. Flag Belt and Flag Removal**

### **Flag Belt and Apparatus**

**ARTICLE 1.** The Flag Belt Apparatus is the required equipment that includes a single belt – to be worn around the waist and on top of all clothing – as well as two flags and couplings that are attached on each hip (left and right side).

### **Flag Removal**

**ARTICLE 2.** The Flag is considered “removed” and the play is dead in the following situations:

- a. When either flag is clearly removed from its belt coupling.
- b. If a flag or belt apparatus inadvertently comes off a ball carrier during a down, the play is ruled dead at that spot. If a flag or belt apparatus inadvertently comes off a non-ball carrier during a down, the play shall be ruled dead once that player possesses the ball.
- c. If a flag is torn into more than one piece or a flag belt is torn off.

**ARTICLE 3.** A defensive player may not intentionally remove the flags of a player who is clearly not in possession of the ball.

### **Flag Guarding**

**ARTICLE 4.** Flag Guarding is the act of physically preventing a defensive player from removing an opponent’s flags. This may include, but is not limited to, the natural swinging of the arms while running.

## **SECTION 6. Forward, Beyond and Forward Progress**

### **Forward, Beyond**

**ARTICLE 1.** Forward, beyond or in advance of, as related to either team, denotes direction toward the opponent’s end line. Converse terms are backward or behind.

### **Forward Progress**

**ARTICLE 2.** Forward progress is a term indicating the end of advancement by the ball carrier or airborne pass receiver of either team and applies to the position of the ball when it becomes dead by rule.

## **SECTION 7. Foul and Violation**

### **Foul**

**ARTICLE 1.** A foul is a rule infraction for which a penalty is prescribed.

### **Personal Foul**

**ARTICLE 2.** A personal foul is a foul involving illegal physical contact that endangers the safety of another player.

### **Flagrant Personal Foul**

**ARTICLE 3.** A flagrant personal foul is illegal physical contact so extreme or deliberate that it places an opponent in danger of catastrophic injury.

### **Violation**

**ARTICLE 4.** A violation is a rule infraction for which no penalty is prescribed. Since it is not a foul, it does not offset a foul.

## **SECTION 8. Fumble, Muff; Batting and Touching the Ball; Blocking a Kick**

### **Fumble**

**ARTICLE 1.** To fumble the ball is to lose player possession by any act other than passing, kicking or successful handing. The status of the ball is a fumble.

### **Muff**

**ARTICLE 2.** To muff the ball is to touch the ball in an unsuccessful attempt to catch or recover it. Muffing the ball does not change its status.

### **Batting**

**ARTICLE 3.** Batting the ball is intentionally striking it or intentionally changing its direction with the hand(s) or arm(s). When in question, the ball is accidentally touched rather than batted. Batting the ball does not change its status.

### **Touching**

**ARTICLE 4. a.** Touching a ball not in player possession denotes any contact with the ball. It may be intentional or unintentional, and it always precedes possession and control.

**b.** Intentional touching is deliberate or intended touching.

**c.** Forced touching results when a player's contact with the ball is due to (i) an opponent blocking a player into it, or (ii) the ball being batted or illegally kicked into that player by an opponent. If the touching is forced, the player in question by rule has not touched the ball.

**d.** When in question, a ball has not been touched on a kick or forward pass.

### **Blocking a Punt**

**ARTICLE 5.** Blocking a punt is touching the kicked ball by an opponent of the kicking team in an attempt to prevent the ball from crossing the neutral zone (Rule 6-2-5-b).

## **SECTION 9. Lines**

### **Sidelines**

**ARTICLE 1.** A sideline runs from end line to end line on each side of the field and is part of the vertical plane that separates the field of play from the area that is out-of-bounds. The entire sideline is out-of-bounds.

### **Goal Lines and Pylons**

**ARTICLE 2.** The goal line at each end of the field of play runs between the sidelines and is part of the vertical plane that separates the end zone from the field of play. The two goal lines are 80 yards apart. The plane of the goal line extends between and includes the pylons, which are out-of-bounds. The entire goal line is in the end zone. A team's goal line is that which it is defending.

### **End Lines**

**ARTICLE 3.** An end line runs between the sidelines 10 yards behind each goal line and separates the end zone from the area that is out-of-bounds. The entire end line is out-of-bounds.

### **Boundary Lines**

**ARTICLE 4.** The boundary lines are the sidelines and the end lines. The area enclosed by the boundary lines is "inbounds", and the area surrounding and including the boundary lines is "out-of-bounds".

### **Yard Lines**

**ARTICLE 5.** A yard line is any line in the field of play parallel to the end lines. A team's own yard lines, marked or unmarked, are numbered consecutively from its own goal line to the 40-yard line

### **Hash Marks**

**ARTICLE 6.** The two hash marks are 15 yards from the sidelines. Hash marks and short yard-line extensions shall measure 24 inches in length.

## **SECTION 10. Handing the Ball**

**ARTICLE 1. a.** Handing the ball is transferring player possession from one teammate to another without throwing, fumbling or kicking it.

- b. Except when permitted by rule, handing the ball forward to a teammate is illegal.
- c. Loss of player possession by unsuccessful execution of attempted handing is a fumble by the last player in possession (**Exception:** The snap).
- d. A backward handoff occurs when the ball carrier releases the ball before it is beyond the yard line where the ball carrier is positioned.

### **SECTION 11. Huddle**

A huddle is two or more players grouped together after the ball is ready for play and before a snap.

### **SECTION 12. Hurdling**

**ARTICLE 1. a.** Hurdling is an attempt by a player to jump with one or both feet or knees foremost over an opponent while that opponent is still on their feet.

- b. "On their feet" means that no part of the opponent's body other than one or both feet is in contact with the ground.

### **SECTION 13. Kicks; Kicking the Ball**

#### **Kicking the Ball; Legal and illegal Kicks**

**ARTICLE 1. a.** Kicking the ball is intentionally striking the ball with the knee, lower leg, or foot.

- b. A legal kick is a punt by a player in possession when such a kick is permitted by Rule. Any punt continues to be a punt until it is caught by a player or becomes dead. Kicking the ball in any other manner is illegal.
- c. When in question, a ball is accidentally touched rather than kicked.

#### **Punt**

**ARTICLE 2.** A punt is a kick by a player who drops the ball and kicks it before it touches the ground. A punt made by A under restrictions that prohibit either team from advancing beyond their scrimmage line until the ball is punted.

### **SECTION 14. Fair Catch**

#### **Fair Catch**

**ARTICLE 1. a.** A fair catch of a punt is a catch beyond the neutral zone by a Team B player who has made a valid signal during a punt that is untouched beyond the neutral zone.

- b. A valid or invalid fair catch signal deprives the receiving team of the opportunity to advance the ball. The ball is declared dead at the spot of the catch or recovery. If the catch precedes the signal, the ball is dead when the signal is first given.
- c. If the receiver shades their eyes from the sun without waving their hand(s), the ball is live and may be advanced.

#### **Valid Signal**

**ARTICLE 2.** A valid signal is a signal given by a player of Team B who has obviously signaled their intention by extending one hand only clearly above their head and waving that hand from side to side of their body more than once.

#### **Invalid Signal**

**ARTICLE 3.** An invalid signal is any waving signal by a player of Team B:

- a. That does not meet the requirements of Article 2 (above); or
- b. That is given after a punt is caught beyond the neutral zone, strikes the ground or touches another player beyond the neutral zone.

### **SECTION 15. The Neutral Zone**

**ARTICLE 1. a.** The neutral zone is the space between the two scrimmage lines extended to the sidelines. Its width is one yard.

- b. The neutral zone is established when the ball is ready for play.

- c. The neutral zone exists until there is a change of team possession, until a kick crosses the neutral zone or until the ball is declared dead.

## **SECTION 16. Encroachment and Offside**

### **Encroachment**

**ARTICLE 1.** After the ball is ready for play, encroachment occurs when an offensive player is in or beyond the neutral zone when the snap is imminent.

### **Offside**

**ARTICLE 2.** After the ball is ready for play, offside occurs when a defensive player:

- a. Is in or beyond the neutral zone when the ball is legally snapped; or
- b. Contacts an opponent beyond the neutral zone before the ball is snapped; or
- c. Contacts the ball before it is snapped; or
- d. Threatens an offensive player positioned on the line, causing an immediate reaction, before the ball is snapped; or
- e. Crosses the neutral zone and charges toward a Team A back.

## **SECTION 17. Passes**

### **Passing**

**ARTICLE 1.** Passing the ball is throwing it. A pass continues to be a pass until it is caught or intercepted by a player or the ball becomes dead.

### **Forward and Backward Pass**

**ARTICLE 2. a.** A pass is forward if the ball first strikes the ground, a player, an official or anything else beyond the spot where the ball is released. All other passes are backward passes.

- b. When in question, the ball is passed and not fumbled during an attempted forward pass.
- c. A snap becomes a backward pass when the snapper releases the ball, other than via a hand-to-hand exchange.

### **Crosses Neutral Zone**

**ARTICLE 3. a.** A legal forward pass has crossed the neutral zone when it first strikes the ground, a player, an official or anything beyond the neutral zone inbounds. It has not crossed the neutral zone when it first strikes the ground, a player, an official or anything in or behind the neutral zone inbounds.

- b. A player has crossed the neutral zone if that player's entire body has been beyond the neutral zone.
- c. A legal forward pass is beyond or behind the neutral zone where it crosses the sideline.

### **Catchable Forward Pass**

**ARTICLE 4.** A catchable forward pass is an untouched legal forward pass beyond the neutral zone to an eligible player who has a reasonable opportunity to catch the ball. When in question, a legal forward pass is catchable.

## **SECTION 18. Penalty**

A penalty is a result imposed by rule against a team that has committed a foul and may include one or more of the following: loss of yardage, loss of down, automatic first down, ejection, subtraction from the game clock.

## **SECTION 19. Scrimmage**

### **Scrimmage Down**

**ARTICLE 1.** A scrimmage down is the action between the two teams during a down that begins with a legal snap. A Try down is a scrimmage down that begins when the referee declares the ball ready for play.

### **Scrimmage Line**

**ARTICLE 2.** The scrimmage line for each team is established when the ball is ready for play. It is the yard line that defines the vertical plane passing through the point of the ball nearest a team's own goal line.

## **SECTION 20. Shift**

**ARTICLE 1. a.** A shift is a simultaneous change of position or stance by two or more offensive players after the ball is ready for play but before a legal snap.

**b.** A shift ends when all players have been motionless for one full second.

**c.** A shift continues if one or more players are in motion before the end of the one second interval.

## **SECTION 21. Snapping the Ball**

**ARTICLE 1. a.** A legal snap is handing or passing the ball backward from its position on the ground with a quick and continuous motion of the hand or hands, with the ball actually leaving the hand or hands in this motion.

**b.** The snap starts when the ball is moved legally and ends when the ball leaves the snapper's hands; the ball then becomes alive.

**c.** Unless moved in a backward direction, the movement of the ball doesn't start a legal snap. It is not a legal snap if the ball is first moved forward or lifted.

**d.** The snap need not go between the snapper's legs; but to be legal, it must be a quick and continuous backward motion.

**e.** The ball must be snapped on or between the hash marks.

## **SECTION 22. Series and Possession Series**

### **Series**

**ARTICLE 1.** A series comprises up to four consecutive downs that each begins with a snap.

### **Possession Series**

**ARTICLE 2.** A possession series is a team's continuous possession of the ball in an extra period. It may consist of one or more series.

## **SECTION 23. Spots**

### **Basic Spot**

**ARTICLE 1.** Benchmark for locating the enforcement spot for penalties.

### **Dead-Ball Spot**

**ARTICLE 2.** The point at which the ball became dead.

### **Enforcement Spot**

**ARTICLE 3.** The point at which the penalty for a foul or the result of a violation is enforced.

### **Inbounds Spot**

**ARTICLE 4.** The intersection of the nearer hash mark line and the yard line passing through either the dead-ball spot or the spot where a penalty leaves the ball in a side zone.

### **Out-of-Bounds Spot**

**ARTICLE 5.** The point at which the ball becomes dead by rule because of going or being declared out-of-bounds.

### **Postpunt Spot**

**ARTICLE 6. a.** The spot where a kick ends.

**b.** When a punt ends in Team B's end zone, the postpunt spot is the 14-yard line.

### **Previous Spot**

**ARTICLE 7.** The point at which the ball was last put in play.

**Spot of the Foul**

**ARTICLE 8.** The point at which a foul occurs. If out-of-bounds between the goal lines, the foul is at the intersection of the nearer hash mark and the yard line extended through the spot of the foul. If out-of-bounds between the goal line and the end line or behind the end line, the foul is in the end zone.

**Spot Where Kick Ends**

**ARTICLE 9.** When a kick is caught or recovered or where it is declared dead by rule.

**Spot Where Run Ends**

**ARTICLE 10.** The spot where the run ends is the point:

- a. Where the ball is declared dead in player possession.
- b. Where player possession is lost on a fumble.
- c. Where handing of the ball occurs.
- d. Where an illegal forward pass is thrown.
- e. Where a backward pass is thrown.
- f. Where an illegal kick is made beyond the line of scrimmage.
- g. Where a return kick occurs.
- h. Where player possession is gained under provisions of the "momentum rule" (Rule 8-4-1 Exceptions).

**Succeeding Spot**

**ARTICLE 11.** The point where the ball is next to be put in play.

**SECTION 24. Team and Player Designations****Teams A and B**

**ARTICLE 1.** Team A is the team designated to put the ball in play. Team B is their opponent. The teams retain these designations until the ball is next ready for play.

**Offensive and Defensive Teams**

**ARTICLE 2.** The offensive team is the team in possession. The defensive team is their opponent.

**Kicker**

**ARTICLE 3.** The kicker is any player who legally punts. A player becomes a kicker when their knee, lower leg, or foot makes contact with the ball before it strikes the ground. The kicker is considered a runner until they punt.

**Passer**

**ARTICLE 4.** The passer is the player who throws a forward pass.

**Player**

**ARTICLE 5.** A player is any participant in the game who is not a substitute or replaced player.

**Runner and Ball Carrier**

- ARTICLE 6. a.** The runner is a player in possession of a live-ball or simulating possession of a live-ball.
- b.** A ball carrier is a runner in possession of a live-ball.

**Snapper**

**ARTICLE 7.** The snapper is the player who snaps the ball.

**Substitute**

**ARTICLE 8. a.** A legal substitute is a replacement for a player or a player vacancy during the interval between downs.

- b. A legal incoming substitute becomes a player when they enter the field of play or end zones and communicate with a teammate or an official, enters the huddle, is positioned in an offensive or a defensive formation, or participates in the play.

#### **Ejected Player**

**ARTICLE 9. a.** An ejected player is one who is declared ineligible for further participation and is not allowed to remain in the team area. This player must leave the playing enclosure under the escort of team personnel before the next play after their ejection. They must remain out of view of the field of play under team supervision for the duration of the game.

#### **Player Inbounds and Out-of-bounds**

**ARTICLE 10. a.** A player is out-of-bounds when any part of their body touches anything other than another player or game official on or outside a boundary. An out-of-bounds player who becomes airborne remains out-of-bounds until they touch the ground inbounds.

- b. An inbounds player is a player who is not out-of-bounds. An inbounds player who becomes airborne remains inbounds until they are out-of-bounds.

### **SECTION 25. Timing Devices**

#### **Game Clock**

**ARTICLE 1.** The game clock is any device under the direction of the appropriate official used to time the 48 minutes of the game.

#### **Play Clock**

**ARTICLE 2.** Each stadium shall have a visual play clock at each end of the playing enclosure. The play clock must be capable of counting down from both 40 seconds and 25 seconds. It should automatically default to 40 seconds and start immediately upon being reset by the play-clock operator when any official signals that the ball is dead after a play.

### **SECTION 26. Play Classification**

#### **Forward Pass Play**

**ARTICLE 1.** A legal forward pass play is the interval between the snap and when a legal forward pass is complete, incomplete, or intercepted.

#### **Running Play**

**ARTICLE 2. a.** A running play is any live-ball action other than a forward pass play or punt play.

- b. A run is that segment of a running play during which a ball carrier has possession.
- c. If a ball carrier loses possession by a fumble, backwards pass or illegal forward pass, the spot where the run ends is the yard line where the ball carrier loses possession. The running play includes the run and the loose-ball action before a player gains or regains possession or the ball is declared dead.

#### **Punt Play**

**ARTICLE 3.** A punt play is the action during the interval between the snap and when a punt comes into player possession or the ball is declared dead by rule.

### **SECTION 27. Field Areas**

#### **Field**

**ARTICLE 1.** The area within the limit lines and includes the limit lines and team areas.

#### **Field of Play**

**ARTICLE 2.** The area enclosed by the sidelines and goal lines.

**End Zone**

**ARTICLE 3.** The rectangle at each end of the field is defined by the goal lines, sidelines and end line. The goal line and goal line pylons are in the end zone. A team's end zone is the one it is defending.

**Playing Enclosure**

**ARTICLE 4.** The area is bounded by the stadium, dome, stands, fences, or other structures. Scoreboards are not considered within the playing enclosure.

**Side Zone**

**ARTICLE 5.** The area between the hash marks and the near sideline.

**SECTION 28. Fighting**

**ARTICLE 1.** Any attempt by a player, coach, or team member in uniform to strike an opponent in a combative manner unrelated to football.

- a. An attempt to strike an opponent with the arm(s), hand(s), leg(s), or foot (feet), whether or not there is contact.
- b. An unsportsmanlike act toward an opponent that causes any opponent to retaliate by fighting.

**SECTION 29. Three-and-One Principle**

**ARTICLE 1.** The Three-and-One Principle of penalty enforcement applies when the penalty statement for a foul does not specify the enforcement spot. Application of this principle is described in Rule 10-2-3.

# RULE 3

## Periods, Time Factors, and Substitutions

---

### Section 1. Pregame and Coin Toss

**ARTICLE 1.** Pregame Warmup. Prior to the game, teams must have access to the field for pregame warm-ups at least 30 minutes before the beginning of the first period. This may be altered in advance through mutual agreement of the teams. (**Exception:** If it is not the first game played in a series, by mutual agreement of the involved teams, the warmup time may be shortened to as few as 15 minutes starting when the previous game's teams have vacated the playing field).

**ARTICLE 2. a.** Three minutes prior to the scheduled starting time, the referee shall conduct a coin toss at midfield in the presence of no more than four captains from each team and another game official, first designating the speaking captain of the visiting team to call the coin toss. Before the second half, the referee will obtain the teams' second half options.

- b.** During the coin toss, each team shall remain in their team area on or behind their respective sideline. The coin toss begins when the captains vacate their respective sideline and ends when they return to their team area.
- c.** The winner of the toss shall either defer their choices to the second half or choose one of the following options:
  - 1.** Choose whether their team will start on offense or defense.
  - 2.** Choose the goal their team will defend.
- d.** The opponent shall exercise the remaining available option.
- e.** For the second half the loser of the toss shall choose option 1 or 2 above. The opponent then chooses the remaining available option.

### Section 2. Start of Each Period

#### First and Third Periods

**ARTICLE 1.** Unless moved by penalty, the ball shall be snapped on the Team A 14-yard line to start the first and third periods.

#### Second and Fourth Periods

**ARTICLE 2.** Between the first and second periods and also between the third and fourth periods, the teams shall defend opposite goal lines.

- a.** The ball shall be relocated at a spot corresponding exactly, in relation to goal lines and sidelines, to its location at the end of the preceding period.
- b.** Team possession, number of the next down, and zone line-to-gain remain unchanged.

#### Extra Periods

**ARTICLE 3. a.** If the game is tied after four periods, the officials shall conduct another coin toss as done prior to the start of the game. There will only be one coin toss prior to the start of overtime. If additional overtime periods are played, the captains shall alternate choices. The choices for the winner of the toss may not defer the choice and must choose one of the following:

- 1.** Whether to start on offense or defense.
  - 2.** Which goal to advance towards for the entirety of overtime.
- b.** The loser of the toss shall exercise the remaining option for the first extra period and shall have the first choice of the two options for the subsequent even-numbered extra periods.

- ARTICLE 4. a. Definition.** An extra period shall consist of two possession series with each team putting the ball in play at the 10-yard line closest to the selected goal. This becomes the opponent's 10-yard line.
- b. Possession Series.** Each team retains the ball during a possession series until it scores or fails to do so in the four allotted downs (unless changed by penalty). The ball remains alive after a change of team possession until it is declared dead. However, Team A may not retain possession if they regain possession after a loss of team possession and do not score during that down. Beginning with the third extra period, a team's possession series will be one play for a one point try from the three-yard line, unless moved by penalty.
- Team A and B designations are the same as defined in Rule 2-24-1.
- c. Scoring.** The team scoring the greater number of points during regulation and extra periods shall be declared the winner. There shall be an equal number of possession series, as described in (b) above, in each extra period, unless Team B scores other than on the try.
- d. Fouls and Penalties.** Fouls and penalties are administered similar to regulation with the following exceptions:
- 1. Automatic First Down Penalties.** Penalties that result in an automatic first down will start a new series of downs but will not change the line to gain, which will remain the goal line.
  - 2. Fouls After a Change of Team Possession.**
    - a.** Penalties against either team are declined by rule in extra periods. (**Exceptions:** Penalties for flagrant personal fouls, dead-ball personal fouls, unsportsmanlike conduct fouls, and live-ball fouls treated as dead-ball fouls are enforced on the succeeding play).
    - b.** A score by a team committing a foul during the down is canceled (**Exception:** Live-ball foul treated as a dead-ball foul).
    - c.** If both teams foul during the down and Team B had not fouled before the change of possession, the fouls cancel and the down is not repeated. (**Exceptions:** Penalties for flagrant personal fouls, dead-ball personal fouls, unsportsmanlike conduct fouls, and live-ball fouls treated as dead-ball fouls are enforced on the succeeding play).
- e. Timeouts.** Each team is allowed one timeout for the entirety of overtime. Timeouts not used in regulation do not carry over into extra periods.

### **Section 3. Playing Time and Intermissions**

#### **Length of Periods and Intermissions**

**ARTICLE 1.** Playing time shall be 48 minutes divided into four periods of 12 minutes each with one-minute intermissions between the first and second periods (first half) and between the third and fourth periods (second half).

- a.** No period shall end until the ball is dead and the referee declares the period ended.
- b.** The intermission between the second and third period of a regular season game shall be 15 minutes, unless shortened before the game by mutual agreement of the administrations of both schools. Immediately after the second period ends, the referee should begin the intermission by signaling to start the game clock.

#### **Timing Adjustments**

**ARTICLE 2.** Before the game starts, playing time and the intermission between periods may be shortened by the referee if they are of the opinion that conditions may interfere with the game or present safety concerns. The four periods must be of equal length if the game is shortened before its start.

- a.** Any time during the game, the playing time of any remaining period or periods may be shortened by mutual agreement of the opposing head coaches and the referee.
- b.** Timing errors on the game clock may be corrected but only in the period in which they occur.
- c.** If the referee has definitive knowledge of the elapsed time, they will reset and appropriately start the game clock.
- d.** Timing errors on a play clock may be corrected by the referee. The play clock shall start again.
- e.** When the play-clock count is interrupted by circumstances beyond the control of either team (without positive knowledge of game clock elapsed time), a new count shall start.
- f.** The 40/25-second clock is not started when the game clock is running with fewer than 40 or 25 seconds, respectively, in a period. The play clock shall be set appropriately and continuously display this time (40 or 25 seconds) and hold.

- g. The game clock should not be stopped if the play clock is started in conflict with paragraph f above.

#### **Extension of Periods**

**ARTICLE 3. a.** A period shall be extended for an untimed down if one or more of the following occurs during a down in which time expires in the second or fourth period:

1. A penalty is accepted for a live-ball foul(s). At the option of the offended team, the period is *not* extended if the foul is by the team in possession and the statement of the penalty includes a loss of down.
  2. There are offsetting fouls.
  3. An official sounds their whistle inadvertently or otherwise incorrectly signals the ball dead.
- b. Additional untimed downs will be played until a down is free of the circumstances in statements 1, 2, and 3 or Rule 3-3-4a above.
  - c. If a touchdown is scored during a down in which time in a period expires, the period is extended for the try (**Exception:** Rule 8-3-2a).

### **Section 4. Timeouts: Starting and Stopping the Clock**

#### **Timeout**

**ARTICLE 1. a.** An official shall signal timeout when the rules provide for stopping the clock or when a timeout is charged to a team or taken by the referee. Other officials should repeat timeout signals. The referee may declare a discretionary timeout for any contingency not covered elsewhere.

- b. When a team's charged timeouts are exhausted and it requests a timeout, the request shall not be acknowledged.
- c. Once the game begins, players shall not practice with a ball on the field of play or the end zones except during the half-time intermission.

#### **Suspending the Game**

**ARTICLE 2. a.** The referee may suspend the game temporarily when conditions warrant such action.

- b. When the game is stopped by actions of a person(s) not subject to the rules, or for any other reasons not specified in the rules, and cannot continue, the referee shall:
  1. Suspend play and direct the players to their team areas.
  2. Refer the problem to those responsible for the game's management.
  3. Resume the game when conditions are satisfactory.
- c. If a game is suspended under Rules 3-4-2-a and b before the end of the fourth period and cannot be resumed, there are four possible options:
  1. Resume the game at a later date;
  2. Terminate the game with a determined final score;
  3. Forfeit of the game; or
  4. Declare a no contest.

The option that takes effect shall be determined by conference policy if both institutions are members of the same conference. In non-conference competition, the directors of athletics at the participating institutions or their designees, in consultation with the coaches, must agree on one of the four options. This agreement will include the final score if the game is terminated (Rule 8-1-2).

In the event that the directors of athletics do not reach an agreement, the conference policy of the home team shall be used to determine the outcome.

- d. If a game is suspended under Rules 3-4-2-a and b after four periods of play and cannot be resumed, the game shall be ruled a tie. The final score shall be the score at the end of the last completed period. (Note: If a winner must be determined in a conference playoff game, conference policy shall determine when and where the game will be resumed).
- e. A suspended game, if resumed, will begin with the same time remaining and under the identical conditions of down, distance, field position and player eligibility.

### **Charged Team Timeouts**

**ARTICLE 3.** Provided teams have timeouts remaining and the ball is dead, an official shall award a team timeout when requested by any player or head coach.

- a. Each team is entitled to three charged team timeouts each half.
- b. Successive charged timeouts may be granted to each team during a dead-ball period, but consecutive charged team timeouts are not allowed by the same team in any dead-ball period.
- c. A head coach must be in or in the vicinity of their team area to request a timeout while the ball is dead.
- d. If a coach believes a rule has been enforced improperly, they may request a conference with the referee. If the rule enforcement is not changed, the coach's team will be charged a timeout or a delay penalty if all timeouts have been used.
  1. Only the referee may stop the clock for a head coach's conference.
  2. A request for a head coach's conference must be made before the ball is next snapped and before the end of the second or fourth period.
  3. After a head coach's conference, the full team timeout is granted if charged by the referee.

### **Injury Timeout**

**ARTICLE 4. a.** In the event of an injured player(s), an official will declare a timeout and the player must leave the game for at least one down.

- b. An injury timeout may follow a charged team timeout.
- c. The referee will declare a timeout for an injured official.
- d. Following a timeout for an injured player of the defensive team, the play clock shall be set at 40 seconds.
- e. *Ten-Second Runoff.* If the player injury is the only reason for stopping the clock with less than one minute in the half, the opponent has the option of a 10-second runoff.
  1. The play clock will be set at 40 seconds for an injury to a player of the defensive team and at 25 seconds for an injury to a player of the offensive team.
  2. If there is a 10-second runoff the game clock will start on the referee's signal. If there is no 10-second runoff the game clock will start on the snap.
  3. The 10-second runoff may be avoided by the use of a charged team timeout if available.
  4. There is no option of a 10-second runoff if there are injuries to opposing players.

### **Length of Timeouts**

**ARTICLE 5. a.** Each timeout will be 60 seconds in length.

- b. The referee shall notify both teams after 45 seconds. They will mark the ball ready for play 15 seconds later.
- c. If the team charged with a timeout wishes to resume play before the expiration of one minute and its opponent indicates readiness, the referee will declare the ball ready.
- d. The length of a referee's timeout depends on the circumstances of each timeout.
- e. Penalty options must be exercised before a team timeout.
- f. The intermission after a safety or try shall be not more than one minute.

## **Section 5. Delays/Clock Tactics**

### **Delaying the Start of a Half**

**ARTICLE 1. a.** Each team shall have its players on the field for the opening play for the scheduled time for the beginning of each half. When both teams refuse to enter the field first for the start of either half, the home team must be the first to enter.

- b. The home management is responsible for clearing the field of play and end zones at the beginning of each half so that the periods may start at the scheduled time. The referee may waive the penalty for circumstances beyond the control of home management.

**PENALTY – Ten yards from the succeeding spot.**

### **Illegal Delay of the Game**

**ARTICLE 2. a.** The officials shall make the ball ready for play consistently throughout the game. The play clock will start its count down from either 40 seconds or 25 seconds, by rule depending on circumstances. A foul for illegal delay occurs if the play clock reaches :00 before the ball is put in play.

**b.** Illegal delay includes:

1. Deliberately advancing the ball well after it is dead.
2. When a team is not ready for play after an intermission between periods, after a score, after a media timeout, or anytime the referee orders the ball put in play.
3. When a team is granted a timeout after having expended its allotted number of timeouts for the half or overtime period.
4. Defensive verbal or auditory tactics that disconcert offensive signals.
5. Defensive actions designed to cause a false start.
6. Putting the ball in play before it is ready for play.
7. Sideline Interference.
8. Action clearly designed to delay the officials from making the ball ready for play.

**PENALTY – Dead-ball foul. Five yards from the succeeding spot.**

### **Unfair Clock Tactics**

**ARTICLE 3.** The referee has the authority to order the game clock or play clock be started or stopped when:

- a. Either team conserves or consumes time in a manner that is obviously unfair.
- b. If the game clock is stopped to complete a penalty for a foul by the team ahead in the score (or either team if the score is tied) inside the last two minutes of a half, it will start on the snap, at the option of the offended team.
- c. The game clock will start on the ready-for-play signal after Team A throws an illegal forward or backward pass to conserve time.

## **Section 6. Starting and Stopping the Clock**

### **First 22 Minutes of Each Half**

**ARTICLE 1.** The game clock will run continuously for the first 22 minutes of each half unless stopped for a(n):

- a. *Team Timeout.* Following a team timeout, the clock will start when the ball is legally snapped.
- b. *Official's Timeout.* Following an official's timeout, the clock will start when the ball is marked ready for play.
- c. *Foul(s) & Penalty Enforcement.* Following penalty enforcement, the clock will start when the ball is ready for play, unless the enforcement begins a period or is after a scoring play.
- d. *Scoring Play.* Following a score, the clock will start when the ball is legally snapped to begin the following succeeding possession. The clock will not run during the Try.
- e. *End of first or third period.* The clock will start when the ball is legally snapped to begin the next period.

### **Last 2 Minutes**

**ARTICLE 2.** Under 2 minutes in each half, the clock will stop on a referee's signal and start on the snap for each of the following:

- a. Incomplete pass.
- b. Legal kick down ends.
- c. Period ends.
- d. Player, fumble, or backward pass ruled out-of-bounds.
- e. Safety.
- f. Team B is awarded a first down.
- g. Team timeout.
- h. Touchback.
- i. Touchdown.

**ARTICLE 3.** Under 2 minutes in each half, the clock will stop on a referee's signal and start when the ball is marked ready for play for each of the following:

- a. First down for Team A.

- b. Head coach conference.
- c. Illegally conserving time.
- d. Inadvertent whistle.
- e. Injury timeout.
- f. Official's timeout.
- g. Team A forward fumble out-of-bounds.
- h. Penalty and enforcement.

**ARTICLE 4.** Whenever one or more incidents from ARTICLE 3 occur in conjunction with any incident from ARTICLE 2, the game clock shall start on the snap.

#### **10-Second Runoff from Game Clock - Foul**

**ARTICLE 5. a.** With the game clock running and less than one minute remaining in either half, before a change of team possession if either team commits a foul that causes the clock to stop immediately, the referee will subtract 10 seconds from the game clock at the option of the offended team. The fouls that fall in this category include but are not limited to:

1. Any foul that prevents the snap (e.g., false start, encroachment, defensive offsides by contact in the neutral zone, etc.).
2. Intentional grounding to stop the clock.
3. Incomplete illegal forward pass.
4. Backward pass thrown out-of-bounds to stop the clock.
5. Any other foul committed with the intent of stopping the clock.

The offended team may accept the yardage penalty and decline the 10-second runoff. If the yardage penalty is declined the 10-second runoff is declined by rule.

- b. The 10-second rule does not apply if the game clock is not running when the foul occurs or if the foul does not cause the game clock to stop immediately (e.g., illegal formation).
- c. After the penalty is administered, if there is a 10-second runoff, the game clock starts on the referee's signal. If there is no 10-second runoff, the game clock starts on the snap. **Note:** This rule supersedes Rule 3-6-4
- d. If the fouling team has a timeout remaining, they may avoid the 10-second runoff by using a timeout. In this case the game clock starts on the snap after the timeout.
- e. The 10-second runoff does not apply when there are offsetting fouls.

## **SECTION 7. Substitutions**

### **Substitutions Procedures**

**ARTICLE 1.** Any number of legal substitutes for either team enter the game between periods, after a score or try, or during the interval between downs only for the purpose of replacing a player(s) or filling a player vacancy(ies).

### **Legal Substitutions**

**ARTICLE 2.** A legal substitute may replace a player or fill a player vacancy provided none of the following restrictions is violated:

- a. No incoming substitute shall enter the field of play or an end zone while the ball is in play.
- b. No player, in excess of 7, shall leave the field of play or end zone while the ball is in play.

#### **PENALTY – Live-ball foul. Five yards from the previous spot.**

- c.
  1. An incoming legal substitute must enter the field of play directly from their team area, and a substitute, player, or departing player must depart at the sideline nearest their team area and proceed to their team area
  2. A departing player must immediately leave the field of play, including the end zones. A departing player who leaves the huddle or their position within three seconds, after a substitute becomes a player, is considered to have left immediately.
- d. Substitutes who become players must remain in the game for at least one play and replaced players must remain out of the game for at least one play, except during the interval between periods, after a score, or when a timeout is charged.

#### **PENALTY – Dead-ball foul; Five yards from the succeeding spot.**

- e. The referee may prevent the ball from becoming live if they deem that the defense has not been afforded ample opportunity to match a substitution made by the offense. If the play clock expires during this period, it is a delay of game penalty against the offense.

**More Than Seven Players on the Field**

**ARTICLE 3. a.** Team A may not break the huddle with more than 7 players nor keep more than 7 players in the huddle or in a formation for more than three seconds. Officials shall stop action whether or not the ball has been snapped.

**PENALTY – Dead-ball foul. Five yards at the previous spot.**

- b. Team B is allowed to briefly retain more than 7 players on the field to anticipate the offensive formation, but it may not have more than 7 players on the field when the ball is snapped. The infraction is treated as a live-ball foul.

**PENALTY – Live-ball foul. Five yards at the previous spot.**

# RULE 4

## Ball in Play, Dead-ball, Out-of-bounds

---

### Section 1. Ball in Play – Dead-ball

#### Dead-ball Becomes Live

**ARTICLE 1.** After a dead-ball is ready for play, it becomes a live-ball when it is legally snapped. A ball snapped before it is ready for play remains dead.

#### Live-ball Becomes Dead

**ARTICLE 2. a.** A live-ball becomes a dead-ball as provided in the rules or when an official sounds their whistle (even though inadvertently) or otherwise signals the ball dead. If an official sounds their whistle inadvertently or otherwise signals the ball dead during a down:

1. When the ball is in player possession, the team in possession may elect to put the ball in play where declared dead or repeat the down.
  2. When the ball is loose from a fumble, backward pass, illegal pass or illegal kick, the team in possession may elect to put the ball in play where possession was lost or repeat the down.
  3. During a legal forward pass or legal kick, then the ball is returned to the previous spot and the down repeated.
  4. After Team B gains possession on the try or during an extra period, then the try is over or the extra-period possession series is ended.
- b. If a foul or violation occurs during any of the above downs, the penalty or violation privilege shall be administered as in any other play situation if not in conflict with other rules.

#### Ball Declared Dead

**ARTICLE 3.** A live-ball becomes dead and an official shall sound their whistle or declare it dead:

- a. When any part of the ball carrier's body, except their hand or foot, touches the ground.
- b. When the ball or a ball carrier goes out-of-bounds.
- c. When a ball carrier has a flag removed legally by an opponent. A flag is removed once it becomes detached from the belt.
- d. When a player gains possession of the ball with their flag(s) detached.
- e. When a touchdown, touchback, safety, or successful try is made.
- f. When the ball strikes the ground following illegal touching by A.
- g. When A catches a punt, or an untouched punt comes to rest and no player attempts to secure it.
- h. When A's punt breaks the plane of B's goal line.
- i. When a forward pass is ruled incomplete.
- j. When there is a simultaneous catch or recovery of a live-ball.
- k. When a backwards pass or fumble strikes the ground. A snapped ball that hits the ground before or after getting to the intended receiver is dead at the spot where it hits the ground.
- l. When a live-ball not in player possession touches anything inbounds other than a player, a player's equipment, an official, an official's equipment or the ground (inadvertent-whistle provisions apply).
- m. When a ball carrier simulates placing their knee on the ground.

#### Ball Ready for Play

**ARTICLE 5.** No player shall put the ball in play before it is ready for play.

**PENALTY—Dead-ball foul. Five yards from the succeeding spot.**

### **Play-Clock Count**

**ARTICLE 6.** The ball shall be put in play within 40 or 25 seconds after it is made ready for play, unless, during that interval, play is suspended. If play is suspended, the play-clock count will start again.

**PENALTY—Dead-ball foul for delay of game. Five yards from the succeeding spot.**

## **Section 2. Out-of-bounds**

### **Player Out-of-bounds**

**ARTICLE 1. a.** A player is out-of-bounds when any part of his person touches anything, other than another player or game official, on or inside a boundary line.

- b.** An out-of-bounds player who becomes airborne remains out-of-bounds until he touches the ground inbounds without simultaneously being out-of-bounds.
- c.** A player who touches a pylon is out-of-bounds.

### **Held Ball Out-of-bounds**

**ARTICLE 2.** A ball in player possession is out-of-bounds when either the ball or any part of the ball carrier touches the ground or anything else that is out-of-bounds, or that is on or outside a boundary line, except another player or game official.

### **Loose Ball Out-of-bounds**

**ARTICLE 3. a.** A ball not in player control is out-of-bounds when it touches the ground, a player, a game official, or anything else that is out-of-bounds, or that is outside a boundary line.

- b.** A ball that touches a pylon is out-of-bounds behind the goal line.
- c.** If a live-ball not in player possession crosses a boundary line and then is declared out-of-bounds, it is out-of-bounds at the crossing point.

### **Out-of-bounds at Forward Point**

**ARTICLE 4. a.** If a live-ball is declared out-of-bounds and the ball does not cross a boundary line, it is out-of-bounds at the ball's most forward point when it was declared dead.

- b.** A touchdown is scored if the ball is inbounds and has broken the plane of the goal line before or simultaneous to the ball carrier going out-of-bounds.
- c.** A receiver who is in the opponent's end zone and contacting the ground is credited with a completion if they reach over the sideline or end line and catch a legal pass.
- d.** The forward most point of the ball when declared out-of-bounds between the goal lines is the point of forward progress (**Exception:** When a ball carrier is airborne as they cross the sideline (including a striding runner), forward progress is determined by the position of the ball as it crosses the sideline).

# RULE 5

## Series of Downs, Line to Gain

---

### Section 1. A Series: Started, Broken, Renewed

#### When To Award Series

**ARTICLE 1. a.** A series of up to four consecutive scrimmage downs shall be awarded to the team that is next to put the ball in play by a snap after a touchback, fair catch, or change in team possession, or to the offensive team to start the first and third period and overtime.

- b.** A new series shall be awarded to Team A if it is in legal possession of the ball on or beyond its zone line to gain when the ball is declared dead.
- c.** A new series shall be awarded to Team B if, after fourth down, Team A has failed to earn a first down.
- d.** A new series shall be awarded to Team B if Team A's punt goes out-of-bounds or comes to rest and no player attempts to secure it.
- e.** A new series shall be awarded to the team in legal possession when the ball is declared dead:
  - 1.** If a change of possession occurs during the down.
  - 2.** If a punt crosses the neutral zone.
  - 3.** If an accepted penalty awards the ball to the offended team.
  - 4.** If an accepted penalty mandates a first down.
- f.** A new series shall be awarded to Team B whenever Team B, after a punt, elects to take the ball at a spot of illegal touching.

#### Line to Gain

**ARTICLE 2. a.** The line to gain in any series shall be the zone in advance of the ball, unless distance has been lost due to penalty or failure to gain. In such case, the original zone in advance of the ball at the beginning of the series of downs is the zone line to gain.

- b.** The line to gain is established when the ball is made ready for play before the first down of the new series.

#### Forward Progress

**ARTICLE 3. a.** The most forward point of the ball when declared dead between the end lines shall be the determining point for if the zone line to gain has been reached.

- b.** There are no measurements. The ball is either across the line to gain or has failed to reach the line to gain.

#### Continuity of Downs Broken

**ARTICLE 4. The continuity of a series of downs is broken when:**

- a.** Team possession of the ball changes during a down.
- b.** A punt crosses the neutral zone, goes out-of-bounds, or comes to rest and no player attempts to secure it.
- c.** At the end of a down, Team A has earned a first down.
- d.** After fourth down, Team A has failed to earn a first down.
- e.** An accepted penalty mandates a first down.
- f.** There is a score.
- g.** A touchback is awarded to either team.
- h.** The second or fourth period ends.

## Section 2. Down and Possession After a Penalty

### Penalty Resulting in a New Series

**ARTICLE 1.** Once a penalty is applied, should the yardage place the ball beyond the original zone line to gain, or awards an automatic first down by rule, the next down will be a first down for the possessing team.

### Foul Before Change of Team Possession

**ARTICLE 2. a.** If a penalty is accepted for a foul that occurs between the goal lines before a change of team possession during a down, the ball belongs to Team A. The down shall be repeated unless the penalty also involves loss of a down, mandates a first down, or leaves the ball on or beyond the zone line to gain.

**b.** If the penalty involves loss of a down, the down shall count as one of the four in the series.

### Foul After Change of Team Possession

**ARTICLE 3.** If a penalty is accepted for a foul that occurs during a down after a change of team possession, the ball belongs to the team in possession when the foul occurred. The down and distance established by any such penalty shall be first down with a new zone line to gain.

### Penalty is Declined

**ARTICLE 4.** If a penalty is declined, the number of the next down shall be whatever it would have been if the foul had not occurred.

### Foul Between Downs

**ARTICLE 5. a.** After a distance penalty incurred between downs, the number of the next down shall be the same as that established before the foul occurred, unless enforcement for a foul by Team B leaves the ball on or beyond the zone line to gain or a penalty mandates a first down.

**b.** The penalty for any dead-ball foul that occurs after the ball is ready for play shall be completed after the zone line to gain is established.

### Foul Between Series

**ARTICLE 6. a.** The penalty for any dead-ball foul (including live-ball fouls treated as dead-ball fouls) that occurs after a series end and before the ball is ready for play shall be completed before the line to gain is established.

**b.** The penalty for any dead-ball foul that occurs after the ball is ready for play shall be completed after the line to gain is established.

### Fouls by Both Teams

**ARTICLE 7.** If offsetting fouls occur during a down, that down shall be repeated.

### Rule Decisions are Final

**ARTICLE 8.** No rule decisions may be changed after the ball is next legally snapped or the second of fourth periods have ended. (**Exception:** The number of a down may be corrected any time within that series of downs or before the ball is legally next put in play after that series).

# RULE 6

## Kicks

---

### Section 1. Kickoff

#### Kickoffs

**ARTICLE 1.** There are no kickoffs. Play starts at the Team A 14-yard line, unless moved by penalty.

### Section 2. Punts

#### Legal Punt

**ARTICLE 1.** A legal punt is a kick made in accordance with the Rules. Quick punts, punts taken before the defense is set to receive the ball, are illegal.

#### Declared Punt

**ARTICLE 2.** On fourth down a team shall declare their intention to punt. The captain/head coach shall notify the team's intent to punt to the Referee. Once declared, the kicking team shall complete the punt prior to the play clock expiring. The selecting team may change their decision after a foul or after a timeout.

#### Crossing the Neutral Zone

**ARTICLE 3.** Neither Team A nor Team B may enter the neutral zone until the ball is kicked.

#### Punting the Ball

**ARTICLE 4. a.** After receiving the snap, the kicker must punt the ball within four seconds in a continuous motion. The kicker is permitted to move forward in the process of kicking the ball.

**b.** A punt made when the kicker's entire body is beyond the line of scrimmage is an illegal kick, a live-ball foul that causes the ball to become dead.

**PENALTY – For an illegal kick beyond the neutral zone (live-ball foul): Five yards from the previous spot and loss of down.**

#### Behind the Neutral Zone

**ARTICLE 5. a.** A punt that fails to cross the neutral zone continues in play. All players may catch or recover the ball behind the neutral zone and advance it.

**b.** The blocking of a punt by an opponent of the kicking team who is not more than three yards beyond the neutral zone is considered to have occurred within or behind that zone. If the blocked punt hits the ground, it is dead at that spot.

**c.** Team A shall punt the ball to themselves or any other A player. Team A may punt the ball only once per down.

#### Beyond the Neutral Zone

**ARTICLE 6. a.** Illegal touching in Team A's endzone is ignored.

### **All Become Eligible**

**ARTICLE 7.** When a punt that has crossed the neutral zone touches a player of the receiving team who is inbounds, any player may catch the ball in flight.

### **Forced Touching Disregarded**

**ARTICLE 8. a.** A player blocked by an opponent into a punt that has crossed the neutral zone shall not, while inbounds, be deemed to have touched the punt.

**b.** An inbounds player touched by a ball either batted or illegally kicked by an opponent is not deemed to have touched the ball.

### **Catch or Recovery by Receiving Team**

**ARTICLE 9.** If a player of the receiving team catches or recovers a punt, the ball continues in play.

### **Catch or Recovery by Kicking Team**

**ARTICLE 10. a.** If a player of the kicking team catches or recovers a punt that has crossed the neutral zone, the ball becomes dead. The ball belongs to the receiving team at the dead-ball spot, unless the kicking team is in legal possession when the ball is declared dead. In the latter case, the ball belongs to the kicking team.

**b.** If opposing players who are each eligible to touch the ball simultaneously catch a punt, the simultaneous possession makes the ball dead. A punt declared dead in joint possession of opposing players is awarded to the receiving team.

### **Out-of-bounds Between the Goal Lines or at Rest Inbounds**

**ARTICLE 11.** If a punt goes out-of-bounds between the goal lines or comes to rest inbounds untouched and no player attempts to secure it, the ball becomes dead and belongs to the receiving team at that spot.

### **Out-of-bounds Behind the Goal Line**

**ARTICLE 12.** If a punt goes out-of-bounds behind a goal line, the ball becomes dead and belongs to the team defending that goal line.

### **Touching Ground On or Behind the Goal Line**

**ARTICLE 12.** If a punt untouched by Team B beyond the neutral zone touches the ground on or behind Team B's goal line, the ball becomes dead belonging to Team B.

### **Loose Behind the Goal Line**

**ARTICLE 13.** If a punt untouched by Team B after crossing the neutral zone is batted in Team B's end zone by a player of Team A, it is a violation for illegal touching. The spot of the violation is Team B's 14-yard line. This is a special case of batting in the end zone and is not a foul.

### **Out-of-Bounds Player**

**ARTICLE 14.** No Team A player who goes out-of-bounds during a punt may return inbounds during the down (**Exception:** This does not apply to a Team A player who is illegally forced out-of-bounds and attempts to return inbounds immediately).

**PENALTY—Live-ball foul. Five yards from the previous spot or if the punt crosses the neutral zone, Five yards from the spot where the subsequent dead-ball belongs to Team B.**

### **Fouls by Kicking Team**

**ARTICLE 15.** Penalties for all fouls by the kicking team other than kick-catch interference during a punt play in which the ball crosses the neutral zone may be enforced either at the previous spot with the down repeated (**Exception:** Penalty option is a safety for fouls in Team A's end zone) or at the spot where the subsequent dead-ball belongs to Team B, at the option of Team B.

### **Section 3. Field Goals**

#### **Field Goals**

**ARTICLE 1.** There are no field goal attempts in this game. Team A must attempt to score by a regular play from scrimmage as outlined in Rule 8-3.

### **Section 3. Kick Catching Interference**

#### **Interference with Opportunity**

**ARTICLE 1. a.** If an inbounds player of the receiving team is located where they could catch a punt that has crossed the neutral zone, and if the player is attempting to do so, they must be given an unimpeded opportunity to catch the kick.

- b.** It is an interference foul if, before the receiver touches the ball, a Team A player enters the area defined by the width of the receiver's shoulders and extends one yard in front of them. When in question it is a foul.
- c.** This protection ends when the kick touches the ground or when any player of Team B muffs or touches a punt beyond the neutral zone.
- d.** If interference with a potential receiver is the result of a player being contacted by an opponent, it is not a foul.

### **Section 4. Fair Catch**

#### **Dead Where Caught or Grounded**

**ARTICLE 1. a.** If a Team B player makes a fair catch, the ball becomes dead where caught and belongs to Team B at that spot.

- b.** If a Team B player makes a valid fair catch signal, the unimpeded opportunity to catch a punt continues if this player muffs the kick and still has the opportunity to complete the catch. If that player (or another Team B player) subsequently catches the kick, the ball is placed where the player making the signal first touched it. This protection terminates when the kick touches the ground.
- c.** Rules pertaining to a fair catch apply only when a punt crosses the neutral zone.
- d.** The purpose of the fair catch provision is to protect the receiver who, using the fair catch signal, agrees they or a teammate will not advance after the catch.
- e.** The ball shall be put in play by a snap by the receiving team at the spot of the catch if the ball is caught.

#### **No Advance**

**ARTICLE 2.** No Team B player shall carry a caught or recovered ball more than two steps in any direction after any Team B player gives a valid or invalid fair catch signal.

#### **Invalid Signals: Catch or Recovery**

**ARTICLE 3. a.** A catch after an invalid signal is not a fair catch, and the ball is dead where caught or recovered.

- b.** If the signal follows a catch or recovery, the ball is dead when the signal is first given.
- c.** Invalid signals beyond the neutral zone apply only to Team B.
- d.** An invalid signal beyond the neutral zone is possible only when the ball has crossed the neutral zone.

# RULE 7

## Snapping, Passing, and Running

---

### SECTION 1. The Scrimmage

#### Starting with a Snap

**ARTICLE 1. a.** The ball shall be put in play by a legal snap.

- b.** No player shall put the ball in play before it is ready for play.
- c.** The ball may not be snapped in a side zone. If the starting point for any scrimmage down is in a side zone, the ball shall be transferred to the hash mark.

#### Shift and False Start

**ARTICLE 2. a. *Shift.*** After a huddle or shift and before the snap, all Team A players must come to an absolute stop and remain stationary in their positions without movement of the feet, body, head or arms for at least one full second before the ball is snapped.

**b. *False Start.*** Each of the following is a false start by Team A if it occurs prior to the snap after the ball is ready for play and all players are in scrimmage formation:

1. Any movement by one or more players that simulates the start of a play.
2. The snapper moving to another position.
3. An offensive player making any quick, jerky movement before the snap, including but not limited to:
  - (a) The snapper shifting or moving the ball, moving their thumb or fingers, flexing their elbows, jerking their head, or dipping their shoulders or buttocks.
  - (b) The quarterback making any quick, jerky movement that simulates the beginning of a play.
  - (c) A back simulating receiving the ball by making any quick, jerky movement that simulates the beginning of a play.
4. The offensive team never coming to a one-second stop prior to the snap after the ball is ready for play. This is an illegal shift that converts to a false start.

#### Offensive Team Requirements—Prior to the Snap

**ARTICLE 3.** Each of the following (a-c) is a dead-ball foul. Officials should blow the whistle and not allow the play to continue. After the ball is ready for play and before it is snapped:

- a. *Snapper.*** The snapper:
  1. May not move to a different position nor have any part of their body beyond the neutral zone;
  2. May not lift the ball, move it beyond the neutral zone or simulate the start of a play;
  3. May take their hand(s) off the ball, but only if this does not simulate the start of a play.
- b. *Encroachment.*** Once the snap is imminent, no other Team A player may be in or beyond the neutral zone (***Exception:*** Substitutes and departing players).
- c. *False Start.*** No Team A player may commit a false start or contact an opponent.

**PENALTY—[a-c] Dead-ball foul: Five yards from the succeeding spot.**

#### Offensive Team Requirements—At the Snap

**ARTICLE 4.** Violation of each of the following (a-c) is a live-ball foul; the play is allowed to continue.

- a. *Formation.*** At the snap Team A must be in a formation that meets these requirements:
  1. All players must be inbounds.
  2. The snap must be received at least 2 yards behind the offensive scrimmage line.
  3. The only player required to be on the offensive scrimmage line is the snapper.
- b. *Player in Motion.***

1. One back may be in motion, but that back may not be moving toward their opponent's goal line.
2. A player in motion at the snap must have satisfied the one-second rule—i.e., that player may not start their motion before any shift has ended.

c. *Illegal Shift.* At the snap, Team A may not execute an illegal shift (Rule 7-1-2-a).

**PENALTY [a-c]—Live-ball foul: Five yards from the previous spot. For live-ball fouls occurring when or after the snap starts during punt plays: Five yards from the previous spot or if the punt crosses the neutral zone, Five yards from the spot where the subsequent dead-ball belongs to Team B.**

### **Defensive Team Requirements**

**ARTICLE 5.** The defensive team requirements are as follows:

- a. Each of the following (1-5) is a dead-ball foul. Officials should blow the whistle and not allow the play to continue. After the ball is ready for play and before the ball is snapped:
  1. No player may touch the ball except when moved illegally, nor may any player contact an opponent or in any other way interfere with them.
  2. No player may enter the neutral zone causing an offensive player to react immediately or commit any other dead-ball offside foul.
  3. No player may cross the neutral zone and without making contact continue their charge toward any player in the offensive backfield.

**PENALTY [1-3]—Dead-ball foul, offside. Five yards from the succeeding spot.**

4. Player(s) aligned in a stationary position one yard from the line of scrimmage may not make quick, abrupt or exaggerated actions that are not part of normal defensive player movement.
5. No player shall use words or signals that disconcert opponents when they are preparing to put the ball in play. No player may call defensive signals that simulate the sound or cadence of, or otherwise interfere with, offensive starting signals.

**PENALTY [4-5]—Dead-ball foul, delay of game. Five yards from the succeeding spot.**

- b. When the snap starts:
  1. No player may be in or beyond the neutral zone at the snap.
  2. All players must be inbounds.

**PENALTY—Live-ball foul. Five yards from the previous spot.**

## **SECTION 2. Running**

### **Flag Guarding**

**ARTICLE 1.** A runner shall not flag guard by using their hands, arms, or the ball to cause contact between the runner and an opponent that denies the opponent the opportunity to pull or remove the flag belt. Examples of flag guarding include, but are not limited to, the following:

- a. Placing or swinging the hand or arm over a flag.
- b. Placing the ball in possession over a flag.
- c. Lowering the shoulders in such a manner that places the arm over the flag belt.
- d. Contacting an opponent with an extended hand or arm.

**PENALTY—Live-ball foul. Five yards from the spot of the foul; also loss of down by Team A before team possession changes during a scrimmage down.**

### **Helping the Ball Carrier or Passer**

**ARTICLE 2. a.** The ball carrier shall not grasp a teammate; and no other player of their team shall grasp, pull, or lift them to assist their forward progress.

- b. Teammates of the ball carrier or passer shall not use interlocked interference by grasping or encircling one another in any manner while contacting an opponent.

**PENALTY—Live-ball foul. Five yards from the succeeding spot.**

### **Holding the Runner**

**ARTICLE 3.** An opponent shall not hold, grasp, or obstruct the forward progress of a runner when in the act of removing the flag belt.

**PENALTY—Live-ball foul. Five yards.**

### **SECTION 3. Backward Pass and Fumble**

#### **During Live-ball**

**ARTICLE 1.** A ball carrier may hand or pass the ball backward at any time, except to throw the ball intentionally out-of-bounds to conserve time.

**PENALTY—Five yards from the spot of the foul; also loss of down if by Team A before team possession changes during a scrimmage down.**

#### **Caught**

**ARTICLE 2. a.** When a backward pass or fumble is caught by any inbounds player, the ball continues in play.

**b.** When a backward pass or fumble is caught simultaneously by opposing players, the ball becomes dead and belongs to the team last in possession.

#### **Out-of-bounds or Grounded**

**ARTICLE 3. a.** Backward Pass. When a backward pass goes out-of-bounds or is grounded between the goal lines, the ball belongs to the passing team at the spot.

**b.** *Fumble.* When a fumble goes out-of-bounds or is grounded between the goal lines:

**1.** In advance of the spot of the fumble, the ball belongs to the fumbling team at the spot of the fumble.

**2.** Behind the spot of the fumble, the ball belongs to the fumbling team at the spot.

**c.** Behind or Beyond the Goal Line. When a fumble or backward pass goes out-of-bounds or is grounded behind or beyond a goal line, it is a safety or touchback depending on impetus and responsibility.

### **SECTION 4. Forward Pass**

#### **Legal Forward Pass**

**ARTICLE 1.** Team A may make one forward pass during each scrimmage down before team possession changes, provided the pass is thrown from a point in or behind the neutral zone.

#### **Illegal Forward Pass**

**ARTICLE 2.** A forward pass is illegal if:

**a.** It is thrown by a Team A player whose entire body is beyond the offensive scrimmage line when the ball is released.

**b.** It is thrown by a Team B player.

**c.** It is thrown after team possession has changed during the down.

**d.** It is the second forward pass during the same down.

**e.** It is thrown from in or behind the offensive scrimmage line after a ball carrier's entire body and the ball have been beyond the offensive scrimmage line.

**f.** If a passer catches their untouched forward pass.

**PENALTY [a-f]—Five yards from the spot of the foul; also loss of down if by Team A before team possession changes during a scrimmage down.**

**g.** The passer to conserve time throws the ball directly to the ground (1) after the ball has already touched the ground; or (2) not immediately after controlling the ball.

**h.** The passer to conserve time throws the ball forward into an area where there is no eligible Team A receiver.

**i.** The passer to conserve yardage throws the ball forward into an area where there is no eligible Team A receiver.

**PENALTY [g-i]—Loss of down at the spot of the foul.**

#### **Eligibility To Touch Legal Forward Pass**

**ARTICLE 3. a.** Eligibility rules apply during a down when a legal forward pass is thrown.

**b.** All Team B players are eligible to touch or catch a pass.

**c.** All Team A players are eligible to touch or catch a pass (**Exception:** Team A player who threw the pass).

**d.** Team A eligible player loses their eligibility when the player goes out-of-bounds.

### Eligibility Lost by Going Out-of-bounds

**ARTICLE 4.** No offensive receiver who goes out-of-bounds and returns inbounds during a down shall touch a legal forward pass while in the field of play or end zones or while airborne until it has been touched by an opponent or official. (**Exception:** This does not apply to an originally eligible offensive player who immediately returns inbounds after going out-of-bounds due to contact by an opponent). If the player touches the pass before returning inbounds, it is an incomplete pass and not a foul for illegal touching.

**PENALTY—Loss of down at the previous spot.**

### Eligibility Gained or Regained

**ARTICLE 5.** When a Team B player or an official touches a legal forward pass, all players become eligible.

### Complete Pass

**ARTICLE 6.** Any forward pass is complete when caught by a player of the passing team who is inbounds, and the ball continues in play unless completed in the opponent's end zone or the pass has been caught simultaneously by opposing players. If a forward pass is caught simultaneously by opposing players inbounds, the ball becomes dead and belongs to the passing team.

### Incomplete Pass

**ARTICLE 7. a.** Any forward pass is incomplete if the ball is out-of-bounds by rule or if it touches the ground when not firmly controlled by a player. It also is incomplete when a player leaves their feet and receives the pass but first lands on or outside a boundary line.

**b.** When a legal forward pass is incomplete, the ball belongs to the passing team at the previous spot.

**c.** When an illegal forward pass is incomplete, the ball belongs to the passing team at the spot of the pass

(**Exception:** If Team B declines the penalty for an illegal pass thrown from the end zone, the ball shall next be put in play at the previous spot).

### Illegal Contact and Pass Interference

**ARTICLE 8. a.** During a down in which a legal forward pass crosses the neutral zone, illegal contact by Team A and Team B players is prohibited from the time the ball is snapped until it is touched by any player or an official.

**b.** Offensive pass interference is contact by a Team A player beyond the neutral zone that interferes with a Team B player during a legal forward pass play in which the forward pass crosses the neutral zone. It is the responsibility of the offensive player to avoid the opponents. It is not offensive pass interference:

1. When two or more eligible players are making a simultaneous and bona fide attempt to reach, catch or bat the pass. Players of either team have equal rights to the ball.
2. When the pass is in flight and two or more players are in the area where they might receive or intercept the pass and an offensive player in that area impedes an opponent, and the pass is not catchable.

**PENALTY—Ten yards from the previous spot.**

**c.** Defensive pass interference is contact beyond the neutral zone by a Team B player whose intent to impede an eligible opponent is obvious and could prevent the opponent the opportunity of receiving a catchable forward pass. When in question, a legal forward pass is catchable. Defensive pass interference occurs only after a legal forward pass is thrown.

It is not defensive pass interference:

1. When two or more eligible players are making a simultaneous and bona fide attempt to reach, catch or bat the pass. Eligible players of either team have equal rights to the ball.
2. When a Team B player legally contacts an opponent before the pass is thrown.

**PENALTY—Team A's ball at the spot of the foul, first down, if the foul occurs fewer than 10 yards beyond the previous spot. If the foul occurs 10 or more yards beyond the previous spot, Team A's ball, first down, Ten yards from the previous spot [S33].**

**When the ball is snapped on or inside the Team B 13-yard line and outside the Team B three-yard line, and the spot of the foul is on or inside the three-yard line, the penalty from the previous spot shall place the ball at the three-yard line, first down.**

**No penalty enforced from outside the three-yard line may place the ball inside the three-yard line (*Exception:* On the Try when the snap is on or inside the three-yard line).**

**If the previous spot was on or inside the three-yard line, first down halfway between the previous spot and the goal line.**

**Pass Interference: Summary**

**ARTICLE 9. a.** Pass interference rules apply only during a down in which a legal forward pass crosses the neutral zone.

- b.** Contact by Team B with an eligible receiver involving a personal foul that interferes with the reception of a catchable pass may be ruled either as pass interference or as a personal foul with the 10-yard penalty enforced from the previous spot. Rule 7-4-8 is specific about contact during a pass. However, if the interference involves an act that ordinarily would result in ejection, the fouling player is ejected from the game.
- c.** Physical contact is required to establish interference.
- d.** Each player has territorial rights, and incidental contact is ruled under “attempt to reach...the pass” in Rule 7-4-8. If opponents who are beyond the line collide while moving toward the pass, a foul by one or both players occurs only if intent to impede the opponent is obvious. It is pass interference only if a catchable forward pass is involved.
- e.** Pass interference rules do not apply after the pass has been touched anywhere inbounds by an inbounds player or has touched an official. If an opponent is fouled, the penalty is for the foul and not pass interference.

# RULE 8

## Scoring

---

### Section 1. Value of Scores

#### Scoring Plays

**ARTICLE 1.** The point value of scoring plays shall be:

- Touchdown – 6 points
- Safety (points awarded to opponent) – 2 points
- Successful try by Team A:
  - Touchdown from the 3-yard line — 1 Point
  - Touchdown from the 10-yard line — 2 Points
  - Safety — 1 Point
- Touchdown during a try after a change of possession – 2 points

#### Forfeited Games

**ARTICLE 2.** The score of a forfeited game, or a suspended game that later results in a forfeit, shall be: Offended Team – 1, Opponent – 0. However, if the offended team is ahead at the time of the forfeit, the score stands.

### Section 2. Touchdown

#### How Scored

**ARTICLE 1.** A touchdown shall be scored when:

- a. A ball carrier advancing from the field of play has possession of a live-ball when it penetrates the plane of the opponent's goal line. This plane extends beyond the pylons only for a player who touches the ground in the end zone or a pylon.
- b. A player catches a forward pass in the opponent's end zone.
- c. A fumble or backwards pass is caught, intercepted, or awarded in the opponent's end zone.
- d. The referee awards a touchdown under the provisions of Rule 9-2-3 (Unfair Acts).

### Section 3. Try Down

#### Referee's Responsibility and Team's Choice

**ARTICLE 1.** The referee must ask the coach or captain whether the try shall be from the 3- or 10-yard line for 1 or 2 points respectively. Once this decision is made, it can only be changed after a charged team timeout. The value of the try may not be changed if a dead-ball foul occurs after the ready for play signal, or if a live-ball foul occurs during the try. Enforcement of penalties does not change the value of the try.

#### Opportunity to Score

**ARTICLE 2.** A try is the opportunity for either team to score one or two points while the game clock is stopped after a touchdown. It is a special interval in the game which, for purposes of penalty enforcement only, includes both a down and the "ready" period that precedes it.

- a. The ball shall be put in play by the team that scored a six-point touchdown. If a touchdown is scored during a down in which time in the fourth period expires or in extra periods, the try is not attempted unless it will affect the outcome of the game. (**Exception:** If the scoring team is ahead by one or two points, they have the option to forgo the try).
- b. The snap will be midway between the hash marks at the yardage declared by the team that scored the six-point touchdown. The ball may be relocated after a Team B foul or a charged timeout to either team unless the timeout is preceded by a Team A foul or offsetting fouls.

- c. A try ends when:
  1. Either team scores.
  2. The ball is dead by rule.
  3. An accepted penalty results in a score.
  4. A Team A loss-of-down penalty is accepted.

#### **Fouls During a Try Before a Change of Team Possession**

**ARTICLE 3. a.** Offsetting fouls: If both teams foul during the down and Team B fouls before the change of possession, the fouls offset and the down is repeated even if additional fouls occur after the change of possession. Any repeat of the down after offsetting fouls must be from the previous spot.

- b. Fouls by Team B on a try:
  1. When the try is successful Team A may accept the score with penalties for personal fouls and unsportsmanlike conduct fouls enforced from the succeeding spot.
  2. A repeat of the down after a penalty against Team B may be from any point on or between the hash marks on or behind the yard line where the penalty leaves the ball.
- c. Fouls by Team A on a Try:
  3. After a foul by Team A on a successful try, the ball shall be put into play at the spot where the penalty leaves it.
  4. If Team A commits a foul for which the penalty carries a loss of down, then the try is over and the score is cancelled, and no yardage is assessed on the succeeding spot.
  5. If before a change of team possession Team A commits a foul that is not offset, and during the down there is neither another change of team possession nor a score, the penalty is declined by rule.
- d. Dead-Ball Enforcement:
  1. Penalties for fouls occurring after the ball is ready for play but before the snap are enforced before the next snap.
  2. Penalties for live-ball fouls treated as dead-ball fouls occurring during the try are enforced on the succeeding spot. If the try is replayed, those penalties are enforced on the replay.

#### **Fouls During a Try After a Change of Team Possession**

**ARTICLE 4. a.** Penalties against either team are declined by rule. (**Exception:** Penalties for flagrant personal fouls, dead-ball unsportsmanlike conduct, dead-ball personal fouls, and live-ball fouls treated as dead-ball fouls are enforced on the succeeding spot).

- b. A score by a team committing a foul during the down is canceled. (**Exception:** Live-ball fouls treated as dead-ball fouls).
- c. If both teams foul during the down and Team B had not fouled before the change of possession, the fouls cancel, the down is not repeated, and the try is over. (**Exception:** Penalties for flagrant personal fouls, dead-ball unsportsmanlike conduct, dead-ball personal fouls, and live-ball fouls treated as dead-ball fouls are enforced on the succeeding spot).

#### **Fouls After a Try**

**ARTICLE 5.** Penalties for fouls occurring after a try are enforced from the succeeding spot. However, if the try is repeated, these penalties are enforced before the repeat.

#### **Next Play**

**ARTICLE 6.** After a try the ball shall be snapped by the opponent of the scoring team at their own 14-yard line, unless moved by penalty or to begin overtime.

## **Section 4. Safety**

#### **How Scored**

**ARTICLE 1.** It is a safety when:

- a. A runner carries the ball from the field of play to or across their own goal line, and it becomes dead there in their team's possession. This includes when a player's backwards pass or fumble from inside their own end zone lands or goes out-of-bounds between the goal lines.

**Exception:**

It is not a safety if a player between their own team's five-yard line and goal line:

- (a) intercepts a pass or fumble; or catches a kick; and
- (b) the player's original momentum carries that player into their own end zone; and
- (c) the ball remains behind that team's goal line and is declared dead in the team's possession there. This includes a fumble that goes from the end zone into the field of play and out-of-bounds.

If conditions (a)-(c) are satisfied above, the ball belongs to this player's team, at the spot where that player gained possession

- b. An accepted penalty for a foul leaves the ball on or behind the offending team's goal line.

**Next Play**

**ARTICLE 2.** After a safety is scored, the ball belongs to the defending team and shall be snapped at their own 14-yard line, unless moved by penalty.

## **Section 5. Touchback**

**When Declared**

**ARTICLE 1.** It is a touchback when:

- a. The ball is out-of-bounds behind a goal line, except from an incomplete forward pass, or becomes dead in the possession of a player on, above, or behind the player's own goal line or when the ball becomes dead not in possession on, above, or behind a team's own goal line and the attacking team is responsible for the ball being there.
- b. Team A's punt breaks the plane of Team B's goal line and Team A is responsible for the ball being there.

**Snap After a Touchback**

**ARTICLE 2.** After a touchback is declared, the ball belongs to the defending team at their own 14-yard line, unless moved by penalty. The snap shall be midway between the hash marks, unless a different position on or between the hash marks is selected by the team designated to put the ball in play before the play clock is at 25 seconds or before any subsequent ready-for-play signal. After the ready-for-play signal, the ball may be relocated after a charged team timeout, unless preceded by a Team A foul or offsetting foul.

## **Section 7. Responsibility and Impetus**

**Responsibility**

**ARTICLE 1.** The team responsible for the ball being out-of-bounds behind a goal line or being dead in the possession of a player on, above, or behind the goal line is the team whose player carries the ball or imparts an impetus to it that forces it on, above, or across the goal line, or is responsible for a loose ball being on, above, or behind the goal line, or incurs a penalty that leaves the ball on or behind the goal line.

**Initial Impetus**

**ARTICLE 2. a.** The impetus imparted by a player who kicks, passes, snaps or fumbles the ball shall be considered responsible for the ball's progress in any direction even though its course is deflected or reversed after striking the ground or after touching an official or a player of either team.

- b. Initial impetus is considered expended and the responsibility for the ball's progress is charged to a player;
  - 1. If that player kicks a ball not in player possession.
  - 2. If the ball comes to rest and that player gives it new impetus by any contact with it, other than through forced touching.
- c. A loose ball retains its original status when there is new impetus.

# RULE 9

## Conduct of Players and Others Subject to the Rules

---

### Section 1. Personal Fouls

All fouls in this section (unless noted) and any other acts of unnecessary roughness are personal fouls. Except as otherwise noted, the penalties for all personal fouls are as follows:

**PENALTY—Personal foul. Ten yards. Flagrant offenders shall be ejected. For dead-ball fouls, Ten yards from the succeeding spot. Penalties for Team A live-ball personal fouls behind the neutral zone are enforced from the previous spot. Safety if the Team A live-ball foul occurs behind Team A's goal line.**

#### Flagrant Fouls

**ARTICLE 1. a.** Before the game, during the game and between periods, all flagrant fouls require ejection. Automatic first down for Team B flagrant personal fouls if not in conflict with other rules.

**b.** Examples of flagrant fouls include but are not limited to:

1. Fighting. (Rule 2-28)
2. Tackling the runner similar to tackle football in which it is obvious that there is no attempt to pull the flag.
3. Any action that fits the definition of Rule 2-7-3.

#### Stripping

**ARTICLE 2.** No player shall strip or attempt to strip the ball from a runner by punching, striking, or grabbing the ball.

#### Striking

**ARTICLE 3.** No player shall make contact with an opponent that is deemed unnecessary, including using knees, fists, locked hands, elbows, or any part of the forearm or hand.

#### Throwing a Runner

**ARTICLE 4.** No player shall throw or push the runner to the ground.

#### Tripping

**ARTICLE 5.** No player shall trip an opponent. Tripping is intentionally using the lower leg or foot to obstruct an opponent below the knee.

#### Charging

**ARTICLE 6.** No player shall initiate contact with an opponent by charging, driving through, running into an opponent, nor by leading with a shoulder or extended elbow.

#### Roughing the Passer

**ARTICLE 7. a.** No defensive player shall unnecessarily rough a passer, when it is obvious the ball has been thrown forward legally.

**b.** Examples of roughing the passer include but are not limited to:

1. Contacting the passer's throwing hand or arm.
2. Any action that is a personal foul as described elsewhere in this section.

**PENALTY—Ten yards and automatic first down. The foul is added to the end of the last run when it ends beyond the neutral zone and there is no change of team possession during the down.**

### **Section 8. Screen Blocking**

**ARTICLE 1.** The offensive screen block shall take place without initiating contact. The screen blocker shall have their hands and arms at their side, behind their back, or against their chest when screen blocking. A player must be on their feet before, during, and after screen blocking. A blocker may use their hand or arm to break a fall or retain their balance.

#### **Screen Blocking Fundamentals**

**ARTICLE 9.** A player who screen blocks shall not do any of the following:

- a. Take a position closer than a normal step when behind a stationary opponent.
- b. Make contact when assuming a position at the side or in front of a stationary opponent.
- c. Take a position so close to a moving opponent that their opponent cannot avoid contact by stopping or changing direction. The speed of the player to be screened will determine where the screener may take their stationary position. This position will vary and may be 1 to 2 normal steps or strides from the opponent.
- d. After assuming their legal screening position, move to maintain it.

#### **Illegal Screen Blocking**

**ARTICLE 10.** Any use of the hands, arms, elbows, legs, or body to initiate contact during an offensive player's screen block is illegal. It is a foul if the blocker creates contact by violating any of the screen blocking fundamentals in Rule 9-1-9.

#### **Blocking and Interlocked Interference**

**ARTICLE 11.** Teammates of a runner or passer may interfere for them by screen blocking but shall not use interlocked interference by grasping or encircling one another in any manner.

#### **Use of Hands or Arms by the Defense**

**ARTICLE 12.** Opponents must go around the offensive player's screen block. The arms and hands may not be used to displace the opponent. A blocker may use their hand or arm to break a fall or retain their balance.

**PENALTY—Ten yards**

#### **Hurdling**

**ARTICLE 13.** There shall be no hurdling. (*Exception: The ball carrier may hurdle an opponent.*)

## **Section 2. Unsportsmanlike Conduct**

Except as otherwise noted, the penalties for all unsportsmanlike conduct fouls are as follows:

**PENALTY—Ten yards. Flagrant offenders shall be ejected. For dead-ball fouls, or for live-ball fouls treated as dead-ball fouls, Ten yards from the succeeding spot.**

#### **Unsportsmanlike Acts**

**ARTICLE 1.** There shall be no unsportsmanlike conduct or any act that interferes with orderly game administration on the part of players, substitutes, coaches, authorized attendants or any other persons subject to the rules, before the game, during the game, or between periods.

a. Specifically prohibited act and conduct include:

1. Using abusive, threatening or obscene language or gestures, or engaging in such acts that provoke ill will or are demeaning to an opponent, to game officials, or to the image of the game, including but not limited to:
  - (a) Pointing the finger(s), hand(s), arm(s) or ball at an opponent, or imitating the slashing of the throat.
  - (b) Taunting, baiting or ridiculing an opponent verbally.
  - (c) Any delayed, excessive, prolonged or choreographed act by which a player (or players) attempts to focus attention upon themselves (or themselves).

- (d) An unopposed ball carrier obviously altering stride when approaching the opponent's goal line.
  - (e) Dead-ball contact fouls such as pushing, shoving, striking, etc. that occur clearly after the ball is dead and that are not part of the game action.
  - (f) Holding an unauthorized conference, or being on the field illegally.
  - (g) No ejected person shall be in view of the field of play.
2. After a score or any other play, no player shall:
- (b) Intentionally kick or spin the ball.
  - (c) Spike the ball into the ground.
  - (d) Throw the ball high into the air.
  - (e) Any other unsportsmanlike act or actions that delay the game.

#### **Flag Removal**

**ARTICLE 2.** No player shall intentionally remove a flag from an opposing player other than the ball carrier.

#### **Deceptive Substitutions**

**ARTICLE 3.** No simulated replacements or substitutions may be used to confuse opponents. No tactic associated with substitutes or the substitution process may be used to confuse opponents.

#### **Unfair Acts**

**ARTICLE 4.** The following are unfair acts:

- a. A team refuses to play within two minutes after being ordered to do so by the referee.
- b. A team repeatedly commits fouls for which penalties can be enforced only by halving the distance to its goal line.
- c. An obviously unfair act not specifically covered by the rules occurs during the game. This includes substitutes, coaches or any other persons subject to the rules, other than a player or official, interfering in any way with the ball or a player while the ball is in play.

**PENALTY—Unsportsmanlike conduct.** The referee may take any action they consider equitable, which includes assessing a Ten yard penalty, directing the down to be repeated, awarding a score, or suspending or forfeiting the game.

#### **Contacting an Official**

**ARTICLE 5.** Persons subject to the rules shall not intentionally contact a game official forcibly during the game.

**PENALTY—Flagrant unsportsmanlike conduct.** Administer as a dead-ball foul. Ten yards from the succeeding spot and automatic ejection.

#### **Game Administration and Sideline Interference**

**ARTICLE 6.** While the ball is live and during the continuing action after the ball has been declared dead:

- a. Coaches, substitutes and authorized attendants in the team area must remain in the team box.

**PENALTY—Administer as a dead-ball foul. First infraction: Warning for sideline interference. No yardage penalty. Second infraction: Delay of game for sideline interference. Five yards from the succeeding spot. Third and subsequent infractions: Team unsportsmanlike conduct for sideline interference. Ten yards from the succeeding spot.**

- b. Physical interference with an official is a foul charged to the team for unsportsmanlike conduct.

**PENALTY—Team unsportsmanlike conduct.** Administer as a dead-ball foul. Ten yards from the succeeding spot.

#### **Ejected Players and Coaches**

**ARTICLE 7.** Any coach, player or identified squad member in uniform who commits two unsportsmanlike conduct fouls in the same game shall be ejected. A player or coach ejected from the game must leave the playing enclosure within a reasonable amount of time after their ejection and must remain out of view of the field for the remainder of the game. A head coach ejected from the game may designate a new head coach.

### **Section 3. Batting and Kicking**

The penalties for all illegal batting and illegal kicking fouls are as follows:

**PENALTY—Five yards.**

#### **Batting a Loose Ball**

**ARTICLE 1.** Players shall not bat a loose ball other than a pass or fumble in flight. (*Exception:* Team A may bat a grounded or an airborne punt beyond A's scrimmage line toward their own goal).

#### **Batting a Backward Pass in Flight**

**ARTICLE 2.** A backward pass in flight shall not be batted or thrown forward by the passing team.

#### **Batting Ball in Possession**

**ARTICLE 3.** A ball in player possession shall not be batted forward by a player of that team.

#### **Illegal Kicking**

**ARTICLE 4.** No player shall intentionally kick a ball other than a punt.

# RULE 10

## Penalty Enforcement

---

### Section 1. Penalties Completed

#### How and When Completed

**ARTICLE 1. a.** A penalty is completed when it is accepted, declined, offset, or canceled according to rule, or when the choice is obvious to the referee.

- b.** Any penalty may be declined. If the yardage of a penalty is declined, the penalty is declined by rule.
- c.** An ejected player must leave the game whether the penalty is accepted, declined, offset or canceled.
- d.** When a foul is committed, the penalty shall be completed before the ball is declared ready for play for any ensuing down.

#### Types of Fouls

**ARTICLE 2. a.** Dead-ball: A foul that occurs prior to a legal snap or after the ball has become dead by rule. This includes live-ball fouls that are treated as dead-ball fouls.

- b.** Live-ball: A foul that occurs during a down.
- c.** Simultaneous With Snap: A foul that occurs as the ball is snapped. These are live-ball fouls considered as occurring during that down.

#### Live-Ball Fouls by the Same Team

**ARTICLE 3.** When two or more live-ball fouls are committed by the same team during the same down, the offended team may elect only one of these penalties. The other fouls are declined by rule.

#### Offsetting Fouls

**ARTICLE 4.** When live-ball fouls are committed by both teams during the same down, the fouls offset and the down is repeated. Live-ball fouls do not offset dead-ball fouls.

##### *Exceptions:*

1. When there is a change of possession during a down, and the team last gaining possession did not foul before last gaining possession, it may refuse offsetting fouls and thereby retain possession after completion of the penalty for its foul.
2. When all Team B fouls that occur before possession changes are governed by postpunt rules, Team B may refuse offsetting fouls and accept postpunt enforcement.
3. During a Try or extra period, Team B fouls committed after it obtained possession.

#### Dead-ball Fouls

**ARTICLE 5.** Penalties for dead-ball fouls are administered separately and in order of occurrence. (*Exception:* When dead-ball unsportsmanlike or dead-ball personal fouls are committed by both teams during the same dead-ball period, and none of the penalties have been completed, the yardage penalties cancel and the number or type of down established before the fouls occurred is unaffected).

### Section 2. Enforcement Procedures

#### Establishing the Line to Gain

**ARTICLE 1. a.** Live-ball Fouls.

1. Enforce the penalty then establish the line to gain.
- b.** Dead-ball Fouls.

1. If the foul occurs prior to the ready for play signal, enforce the penalty then establish the line to gain. (**Exception:** If Team A commits a delay of game foul for snapping the ball prior to the ready for play whistle, the line to gain will be what it would have been had this foul not occurred).
2. If the foul occurs after the ready for play signal, the line to gain will remain the same as what it was when the ready for play signal was blown.

#### **Determining the Spot of Enforcement and the Basic Spot**

**ARTICLE 2. a.** For many fouls, the enforcement spot is specified in the statement of the penalty. When the enforcement spot is not specified in the statement of the penalty, the enforcement spot is determined by the Three-and-One Principle.

- b.** Personal fouls and screen blocking fouls by the offense committed behind the neutral zone are enforced from the previous spot.
- c.** The basic spot of enforcement for live-ball fouls are as follows:
  1. Running plays prior to a change of team possession.
    - (a) Previous spot, when the related run ends behind the neutral zone.
    - (b) End of the related run, when the related run ends beyond the neutral zone.
    - (c) End of the related run, on running plays that have no neutral zone.
  2. Running plays following a change of team possession.
    - (a) End of the related run, when the run does not end in the end zone.
    - (b) Succeeding spot, when a foul occurs after a change of team possession in the end zone and the result of the play is a touchback.
    - (c) Goal line, when a foul occurs after a change of team possession in the field of play and the related run ends in the end zone.
    - (d) Goal line, when a foul occurs after a change of team possession in the end zone, the related run ends in the end zone, and the result of the play is not a touchback.
  3. Loose ball plays: Previous spot.
  4. Punt plays.
    - (a) Previous spot, unless the foul is governed by post punt rules.
    - (b) Post punt spot, if the foul is governed by post punt rules.
    - (c) Fouls by Team A during a punt play (except for Kick Catch Interference) are enforced at either the previous spot, or at the spot where the subsequent dead-ball belongs to Team B, at the option of Team B.
  5. Simultaneous with snap fouls: Previous spot.

#### **Three-and-One Principle**

**ARTICLE 3. a.** For many fouls, the enforcement spot is specified in the statement of the penalty. When the enforcement spot is not specified in the statement of the penalty, the enforcement spot is determined by the Three-and-One Principle.

- b.** When the team in possession commits a foul behind the basic spot, the penalty is enforced at the spot of the foul.
- c.** When the team in possession commits a foul beyond the basic spot, the penalty is enforced at the basic spot.
- d.** When the team not in possession commits a foul either behind or beyond the basic spot, the penalty is enforced at the basic spot.

#### **Post Punt Enforcement**

**ARTICLE 4. a.** Under post punt enforcement rules, fouls by Team B that satisfy the following conditions are treated as if Team B had been in possession at the time the foul was committed, even though by rule team possession had not yet changed.

- b.** Post punt enforcement applies only to Team B fouls during a punt under the following conditions:
  1. The ball crosses the neutral zone.
  2. The foul occurs before the end of the kick.
  3. Team B will next put the ball in play.

If these conditions are all met, the penalty is enforced according to the Three-And-One Principle. Team B is taken as the team in possession with the post punt spot as the basic spot. The post punt spot is the 14-yard line if the kick ends in Team B's end zone.

#### **Fouls During or After a Touchdown or Try**

**ARTICLE 5. a.** If there is a live-ball foul by the scoring team during a down that results in a touchdown, the acceptance of the penalty nullifies the score.

- b.** Fouls by the non-scoring team during a down that ends in a touchdown, and there was not a change of team possession during the down:
  - 1.** Ten yard penalties are enforced on the try, the succeeding spot after the try, or from the succeeding spot in extra periods at the option of the scoring team.
  - 2.** Five yard penalties are not enforced and are declined by rule.
- c.** Fouls by the non-scoring team during a down that ends in a touchdown, and there was a change of team possession during the down:
  - 1.** Ten yard penalties committed following the change of team possession are enforced on the try, the succeeding spot after the try, or from the succeeding spot in extra periods at the option of the scoring team.
  - 2.** Five yard penalties are not enforced and are declined by rule.
- d.** When a foul occurs after a touchdown but before the ball is ready for play on the try, or there was a live-ball foul treated as a dead-ball foul on the touchdown play, enforcement is on the try, the succeeding spot after the try, or from the succeeding spot in extra periods at the option of the scoring team.

#### **Half-Distance Enforcement Procedures**

**ARTICLE 6.** No distance penalty, including on the try, shall exceed half the distance from the enforcement spot to the offending team's goal line. (**Exceptions:** Defensive pass interference during scrimmage downs, other than a try; and (2) on the try, defensive pass interference when the ball is snapped from outside the 3-yard line).

# RULE 11

## The Officials: Jurisdiction and Duties

---

### SECTION 1. Jurisdiction

**ARTICLE 1.** The officials' jurisdiction begins 30 minutes before the scheduled start and ends when the referee declares the score final. It is expected that all officials will be on the field 30 minutes prior to the game start time.

**ARTICLE 2.** At 30 minutes before the start of the game, the playing field will be divided in half, with a buffer zone of 10-yards between the 35 yard-lines in which no player shall enter.

### SECTION 2. Responsibilities

**ARTICLE 1.** The game shall be played under supervision of three, four, or five game officials.

**ARTICLE 2.** Officiating responsibilities and mechanics are specified in the current mechanics set forth by this advisory board. Officials are responsible for knowing and applying the materials.